

SAMSUNG

RAC

Technical Data Book

AR80H for Europe
(R32, 50Hz, Heat Pump)

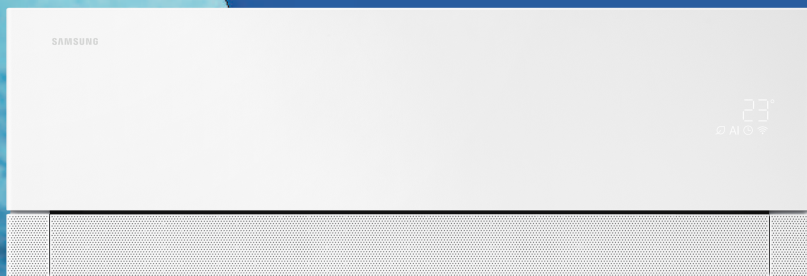

History

Version	Modification	Date
Ver. 1.0	Released AR80H for Europe TDB	25.12.03

Nomenclature

Indoor Unit

Model Name

AR	70	H	09	C	A	A	W	N	EU
(1)	(2)	(3)	(4)	(5)	(6)	(7)	(8)	(9)	Buyer

(1) Classification

AR	RAC
-----------	-----

(2) Series

50	(Entry)	Wind /
60	(Standard)	Wind Free
70	(Deluxe)	Wind Free / PM2.5
80	(Premium)	Wind Free / PM1.0
90	(Infinite)	Wind Free / PM1.0 Temp&Humid Control

(3) Year

H	2026
----------	------

(4) Capacity

	x1000 Btu/h
--	-------------

(5) Product type

C	INVERTER, Heat Pump, R32
D	INVERTER, Cooling Only, R32

(6) AI Level

4	Vision / MOV / Set Bixby / Radar / Wi-Fi
3	MOV / Set Bixby / Radar / Wi-Fi
2	Set Bixby / MDS, CSI / Wi-Fi
A	MDS / Wi-Fi
1	Wi-Fi
0	-

(7) Version

	A-Z, 1~9 (1 digit)
--	--------------------

(8) Color & Design

W	White / Geo
B	Black / Airise
H	White / Airise
M	Mint / Bespoke
G	Grey / Bespoke

(9) Set









N	Indoor Unit
X	Outdoor Unit
/	Set

Contents

1. Line-Up	5
2. Specification	7
3. Summary Table	17
4. Capacity Table	19
5. Dimensional Drawing	32
6. Center of Gravity	36
7. Electrical Wiring Diagram	40
8. Sound Data	42
9. Temperature and Air Flow Distribution	56
10. Operation Range	63
11. Capacity Correction	64
12. Piping Diagram	66

1. Line-Up













Indoor Unit

Model Type	Design	Image	
Première Plus	GRID		
Première Plus Black	GRID		
Première	GRID		
Première Black	GRID		

Model Type	Design	Capacity (Btu/h)					
		07	09	12	15	18	24
Première Plus	GRID		●	●			
Première Plus Black	GRID		●	●			
Première	GRID	●	●	●	●	●	●
Première Black	GRID	●	●	●			

1. Line-Up

Outdoor Unit

Model Type	Capacity (Btu/h)					
	07	09	12	15	18	24
Première Plus						
Première Plus Black						
Première						
Première Black						

2. Specification

Première Plus

System	Model Code	Indoor Unit		-	AR70H09CAAWNEU	AR70H12CAAWNEU		
		Outdoor Unit		-	AR70H09CAAWXEU	AR70H12CAAWXEU		
	Mode				-	Heat Pump	Heat Pump	
	Performance	Capacity	Cooling	Min / Std. / Max	kW	1.0 / 2.5 / 4.0	1.0 / 3.5 / 4.8	
					Btu/h	3,410 / 8,530 / 13,650	3,410 / 11,940 / 16,380	
			Heating	Min / Std. / Max	kW	0.8 / 3.2 / 7.1	0.8 / 4.0 / 7.3	
					Btu/h	2,560 / 10,920 / 24,230	2,560 / 13,650 / 24,910	
	Power	Power Input	Cooling	Min / Std. / Max	kW	0.16 / 0.52 / 1.07	0.16 / 0.85 / 1.40	
			Heating	Min / Std. / Max	kW	0.14 / 0.68 / 2.16	0.14 / 0.94 / 2.28	
		Current Input	Cooling	Min / Std. / Max	A	1.50 / 2.80 / 4.70	1.50 / 3.80 / 6.20	
			Heating	Min / Std. / Max	A	1.10 / 3.10 / 9.50	1.10 / 4.20 / 10.00	
	Efficiency	Cooling	EER		W/W	4.81	4.12	
			SEER		W/W	9.70	9.00	
			SEER	Energy Grade	-	A+++	A+++	
			Pdesignc		kW	2.50	3.50	
		Heating	COP		W/W	4.74	4.26	
			SCOP	Warmer	W/W	6.00	6.00	
				Average	W/W	5.10	5.10	
				Warmer(Energy Grade)	-	A+++	A+++	
				Average(Energy Grade)	-	A+++	A+++	
			Pdesignh	Average	kW	2.40	2.40	
	Warmer	kW		1.30	1.30			
	Piping Connections	Liquid Pipe	Type		-	Flaring	Flaring	
			Diameter		mm	6.35	6.35	
						in	1/4	1/4
		Gas Pipe	Type		-	Flaring	Flaring	
			Diameter		mm	9.52	9.52	
				in	3/8	3/8		
Heat Insulation				-	Both liquid and gas pipes	Both liquid and gas pipes		
Piping length (ODU-IDU)		Max.	m	20	20			
Level difference (ODU-IDU)		Max.	m	10	10			
Wiring Connection	Power Source Wire			mm ²	1.5	1.5		
	Transmission Cable	Min.		mm ²	0.75	0.75		
		Remark		-	F1,F2	F1,F2		
Refrigerant	Type			-	R32	R32		
	Factory Charge			kg	1.0	1.0		
				tCO2e	0.65	0.65		
Sound Level	Sound Pressure Level	Cooling	High / Silent	dB(A)	38 / 16	40 / 16		
	Sound Power Level	Cooling		dB(A)	56	58		
Indoor Unit	Power Supply			⊕ # V Hz	1 2 220-240 50	1 2 220-240 50		
	Heat Exchanger	Type		-	F&T	F&T		
		Material	Fin		-	Al	Al	
			Tube		-	Cu	Cu	
		Fin Treatment			-	Hydrophile	Hydrophile	
	Fan	Type		-	Crossflow	Crossflow		
		Quantity		EA	1	1		
		Air Flow Rate	Cooling	Turbo / High / Mid / Low	CMM	10 / 9 / 8 / 7	11 / 10 / 8 / 7	
						l/s	168 / 152 / 135 / 110	185 / 160 / 135 / 110
			Heating	Turbo / High / Mid / Low	CMM	12 / 11 / 10 / 9	12 / 11 / 9 / 8	
				l/s	202 / 185 / 168 / 143	202 / 177 / 152 / 127		
	Fan Motor	Type			-	BLDC	BLDC	
Quantity			EA	1	1			

2. Specification

Première Plus

System	Model Code	Indoor Unit		-	AR70H09CAAWNEU	AR70H12CAAWNEU	
		Outdoor Unit		-	AR70H09CAAWXEU	AR70H12CAAWXEU	
Indoor Unit	Fan Motor	Output		W	27	27	
	Drain	Drain Pipe	Diameter	-	Ø16.3, 550mm	Ø16.3, 550mm	
		Net Weight		kg	11.3	11.3	
	External Dimension	Shipping Weight		kg	13.2	13.2	
		Net Dimensions	W x H x D	mm	889 x 299 x 230	889 x 299 x 230	
		Shipping Dimensions	W x H x D	mm	950 x 320 x 375	950 x 320 x 375	
	Additional Accessories	Individual Control	Wireless Controller		-	Included	Included
			Wired Controller		-	-	-
		Motion Detect Sensor		-	0	0	
		Easy Filter Plus		-	0	0	
Smart Function	WiFi	WiFi Embedded	-	0	0		
Outdoor Unit	Power Supply			Φ # V Hz	1 2 220-240 50	1 2 220-240 50	
	Performance	kW		-	2.5	3.5	
	Casing	Material	Body	-	EGI Steel Plate / PP	EGI Steel Plate / PP	
		Type		-	F&T	F&T	
	Heat Exchanger	Material	Fin	-	Al	Al	
			Tube	-	Cu	Cu	
		Fin Treatment		-	Hydrophile	Hydrophile	
	Compressor	Model Name		-	KTN130D42UFR	KTN130D42UFR	
		Quantity		EA	1	1	
		Type		-	TWIN_ROTARY	TWIN_ROTARY	
		Oil	Type	-	POE	POE	
	Initial Charge		cc	350	350		
	Fan	Type		-	Propeller	Propeller	
		Discharge direction		-	Horizontal	Horizontal	
		Quantity		EA	1	1	
		Air Flow Rate		CMM	45	45	
	l/s			750	750		
	Fan Motor	Type		-	BLDC	BLDC	
		Quantity		EA	1	1	
		Output		W	45	45	
	Sound Level	Sound Pressure Level	Cooling	dB(A)	45	46	
		Sound Power Level	Cooling	dB(A)	59	62	
	External Dimension	Net Weight		kg	30.5	30.5	
		Shipping Weight		kg	32.5	32.5	
		Net Dimensions	W x H x D	mm	790 x 548 x 285	790 x 548 x 285	
		Shipping Dimensions	W x H x D	mm	913 x 622 x 371	913 x 622 x 371	
	Operating Temp. Range	Cooling	Min. ~ Max.	°C	-10 ~ 46	-10 ~ 46	
Heating		Min. ~ Max.	°C	-15 ~ 24	-15 ~ 24		

NOTE

- Specifications may be subject to change without prior notice.
- 1) Nominal cooling capacities are based on;
 - Indoor temperature: 27°C DB, 19°C WB
 - Outdoor temperature: 35°C DB, 24°C WB, Equivalent refrigerant piping: 5m, Level differences: 0 m
- 2) Nominal heating capacities are based on;
 - Indoor temperature: 20°C DB, 15°C WB
 - Outdoor temperature: 7°C DB, 6°C WB, Equivalent refrigerant piping: 5m, Level differences: 0 m
- 3) Sound pressure was acquired in an anechoic room. Thus actual noise level may be different depending on the installation conditions.
- 4) These products contain R32 which is fluorinated greenhouse gas.

2. Specification

Première Plus Black

System	Model Code	Indoor Unit		-	AR70H09CAABNEU	AR70H12CAABNEU	
		Outdoor Unit		-	AR70H09CAAWXEU	AR70H12CAAWXEU	
	Mode				-	Heat Pump	Heat Pump
	Performance	Capacity	Cooling	Min / Std. / Max	kW	1.0 / 2.5 / 4.0	1.0 / 3.5 / 4.8
					Btu/h	3,410 / 8,530 / 13,650	3,410 / 11,940 / 16,380
			Heating	Min / Std. / Max	kW	0.8 / 3.2 / 7.1	0.8 / 4.0 / 7.3
					Btu/h	2,560 / 10,920 / 24,230	2,560 / 13,650 / 24,910
	Power	Power Input	Cooling	Min / Std. / Max	kW	0.16 / 0.52 / 1.07	0.16 / 0.85 / 1.40
			Heating	Min / Std. / Max	kW	0.14 / 0.68 / 2.16	0.14 / 0.94 / 2.28
		Current Input	Cooling	Min / Std. / Max	A	1.50 / 2.80 / 4.70	1.50 / 3.80 / 6.20
			Heating	Min / Std. / Max	A	1.10 / 3.10 / 9.50	1.10 / 4.20 / 10.00
	Efficiency	Cooling	EER		W/W	4.81	4.12
			SEER		W/W	9.70	9.00
			SEER	Energy Grade	-	A+++	A+++
			Pdesignc		kW	2.50	3.50
		Heating	COP		W/W	4.74	4.26
			SCOP	Warmer	W/W	6.00	6.00
				Average	W/W	5.10	5.10
				Warmer(Energy Grade)	-	A+++	A+++
				Average(Energy Grade)	-	A+++	A+++
			Pdesignh	Average	kW	2.40	2.40
	Warmer	kW		1.30	1.30		
	Piping Connections	Liquid Pipe	Type		-	Flaring	Flaring
			Diameter		mm	6.35	6.35
				in	1/4	1/4	
		Gas Pipe	Type		-	Flaring	Flaring
			Diameter		mm	9.52	9.52
		in	3/8	3/8			
Heat Insulation			-	Both liquid and gas pipes	Both liquid and gas pipes		
Piping length (ODU-IDU)		Max.	m	20	20		
Level difference (ODU-IDU)		Max.	m	10	10		
Wiring Connection	Power Source Wire			mm ²	1.5	1.5	
	Transmiss on Cable	Min.		mm ²	0.75	0.75	
		Remark		-	F1,F2	F1,F2	
Refrigerant	Type			-	R32	R32	
	Factory Charge			kg	1.0	1.0	
				tCO2e	0.65	0.65	
Sound Level	Sound Pressure Level	Cooling	High / Silent	dB(A)	38 / 16	40 / 16	
	Sound Power Level	Cooling		dB(A)	56	58	
Indoor Unit	Power Supply			⊕ # V Hz	1 2 220-240 50	1 2 220-240 50	
	Heat Exchanger	Type		-	F&T	F&T	
		Material	Fin		-	Al	Al
			Tube		-	Cu	Cu
		Fin Treatment			-	Hydrophile	Hydrophile
	Fan	Type		-	Crossflow	Crossflow	
		Quantity			EA	1	1
		Air Flow Rate	Cooling	Turbo / High / Mid / Low	CMM	10 / 9 / 8 / 7	11 / 10 / 8 / 7
					l/s	168 / 152 / 135 / 110	185 / 160 / 135 / 110
			Heating	Turbo / High / Mid / Low	CMM	12 / 11 / 10 / 9	12 / 11 / 9 / 8
	l/s				202 / 185 / 168 / 143	202 / 177 / 152 / 127	
	Fan Motor	Type			-	BLDC	BLDC
Quantity			EA	1	1		

2. Specification

Première Plus Black

System	Model Code	Indoor Unit		-	AR70H09CAABNEU	AR70H12CAABNEU	
		Outdoor Unit		-	AR70H09CAAWXEU	AR70H12CAAWXEU	
	Fan Motor	Output		W	27	27	
	Drain	Drain Pipe	Diameter	-	Ø16.3, 550mm	Ø16.3, 550mm	
Indoor Unit	External Dimension	Net Weight		kg	11.3	11.3	
		Shipping Weight		kg	13.2	13.2	
		Net Dimensions		W x H x D	mm	889 x 299 x 230	889 x 299 x 230
		Shipping Dimensions		W x H x D	mm	950 x 320 x 375	950 x 320 x 375
	Additional Accessories	Individual Control	Wireless Controller		-	Included	Included
			Wired Controller		-	-	-
		Motion Detect Sensor		-	0	0	
Easy Filter Plus		-	0	0			
Smart Function	WiFi	WiFi Embedded		-	0	0	
Outdoor Unit	Power Supply			Φ # V Hz	1 2 220-240 50	1 2 220-240 50	
	Performance	kW		-	2.5	3.5	
	Casing	Material	Body		-	EGI Steel Plate / PP	EGI Steel Plate / PP
		Type		-	F&T	F&T	
	Heat Exchanger	Material	Fin		-	Al	Al
			Tube		-	Cu	Cu
		Fin Treatment		-	Hydrophile	Hydrophile	
	Compressor	Model Name		-	KTN130D42UFR	KTN130D42UFR	
		Quantity		EA	1	1	
		Type		-	TWIN_ROTARY	TWIN_ROTARY	
		Oil	Type		-	POE	POE
	Initial Charge		cc	350	350		
	Fan	Type		-	Propeller	Propeller	
		Discharge direction		-	Horizontal	Horizontal	
		Quantity		EA	1	1	
		Air Flow Rate		CMM	45	45	
	l/s			750	750		
	Fan Motor	Type		-	BLDC	BLDC	
		Quantity		EA	1	1	
		Output		W	45	45	
	Sound Level	Sound Pressure Level	Cooling		dB(A)	45	46
		Sound Power Level	Cooling		dB(A)	59	62
	External Dimension	Net Weight		kg	30.5	30.5	
Shipping Weight		kg	32.5	32.5			
Net Dimensions		W x H x D	mm	790 x 548 x 285	790 x 548 x 285		
Shipping Dimensions		W x H x D	mm	913 x 622 x 371	913 x 622 x 371		
Operating Temp. Range	Cooling		Min. ~ Max.	°C	-10 ~ 46	-10 ~ 46	
	Heating		Min. ~ Max.	°C	-15 ~ 24	-15 ~ 24	

NOTE

- Specifications may be subject to change without prior notice.
- 1) Nominal cooling capacities are based on;
 - Indoor temperature: 27°C DB, 19°C WB
 - Outdoor temperature: 35°C DB, 24°C WB, Equivalent refrigerant piping: 5m, Level differences: 0 m
- 2) Nominal heating capacities are based on;
 - Indoor temperature: 20°C DB, 15°C WB
 - Outdoor temperature: 7°C DB, 6°C WB, Equivalent refrigerant piping: 5m, Level differences: 0 m
- 3) Sound pressure was acquired in an anechoic room. Thus actual noise level may be different depending on the installation conditions.
- 4) These products contain R32 which is fluorinated greenhouse gas.

2. Specification

Première

Model Code	Indoor Unit			-	AR70H07C1AWNEU	AR70H09C1AWNEU	AR70H12C1AWNEU	
	Outdoor Unit			-	AR70H07C1AWXEU	AR70H09C1AWXEU	AR70H12C1AWXEU	
Mode				-	Heat Pump	Heat Pump	Heat Pump	
Performance	Capacity	Cooling	Min / Std. / Max	kW	1.0 / 2.0 / 3.2	1.0 / 2.5 / 3.7	1.0 / 3.5 / 4.6	
				Btu/h	3,280 / 6,820 / 10,920	3,280 / 8,530 / 12,630	3,410 / 11,940 / 15,700	
		Heating	Min / Std. / Max	kW	0.7 / 2.2 / 6.7	0.7 / 3.2 / 7.0	0.7 / 4.0 / 7.2	
				Btu/h	2,390 / 7,510 / 22,860	2,390 / 10,920 / 23,890	2,220 / 13,650 / 24,570	
Power	Power Input	Cooling	Min / Std. / Max	kW	0.17 / 0.43 / 0.84	0.17 / 0.57 / 0.96	0.18 / 0.90 / 1.40	
				Heating	kW	0.15 / 0.46 / 2.25	0.15 / 0.76 / 2.20	0.13 / 1.07 / 2.40
	Current Input	Cooling	Min / Std. / Max	A	1.50 / 2.30 / 3.70	1.50 / 3.00 / 4.30	1.50 / 4.00 / 6.10	
				Heating	A	1.30 / 2.30 / 9.80	1.30 / 3.40 / 10.00	1.20 / 4.70 / 10.50
Efficiency	Cooling	EER		W/W	4.65	4.39	3.89	
		SEER		W/W	9.00	8.80	8.60	
		SEER	Energy Grade	-	A+++	A+++	A+++	
		Pdesignc		kW	2.00	2.50	3.50	
	Heating	COP		W/W	4.78	4.21	3.74	
		SCOP	Warmer	W/W	5.70	5.70	5.70	
			Average	W/W	4.80	4.80	4.80	
			Warmer(Energy Grade)	-	A+++	A+++	A+++	
			Average(Energy Grade)	-	A++	A++	A++	
		Pdesignh	Average	kW	2.20	2.30	2.40	
Warmer	kW		1.30	1.30	1.30			
Piping Connections	Liquid Pipe	Type		-	Flaring	Flaring	Flaring	
		Diameter		mm	6.35	6.35	6.35	
			in	1/4	1/4	1/4		
	Gas Pipe	Type		-	Flaring	Flaring	Flaring	
		Diameter		mm	9.52	9.52	9.52	
			in	3/8	3/8	3/8		
	Heat Insulation			-	Both liquid and gas pipes	Both liquid and gas pipes	Both liquid and gas pipes	
	Piping length (ODU-IDU)		Max.	m	20	20	20	
Level difference (ODU-IDU)		Max.	m	10	10	10		
Wiring Connection	Power Source Wire			mm ²	1.5	1.5	1.5	
	Transmiss on Cable	Min.		mm ²	0.75	0.75	0.75	
		Remark		-	F1,F2	F1,F2	F1,F2	
Refrigerant	Type			-	R32	R32	R32	
	Factory Charge			kg	1.0	1.0	1.0	
				tCO2e	0.64	0.64	0.64	
Sound Level	Sound Pressure Level	Cooling	High / Silent	dB(A)	37 / 16	38 / 16	40 / 16	
	Sound Power Level	Cooling		dB(A)	56	56	58	
Indoor Unit	Power Supply			Φ # V Hz	1 2 220-240 50	1 2 220-240 50	1 2 220-240 50	
	Heat Exchanger	Type		-	F&T	F&T	F&T	
		Material	Fin		-	Al	Al	Al
			Tube		-	Cu	Cu	Cu
	Fin Treatment			-	Hydrophile	Hydrophile	Hydrophile	
	Fan	Type		-	Crossflow	Crossflow	Crossflow	
		Quantity		EA	1	1	1	
		Air Flow Rate	Cooling	Turbo / High / Mid / Low	CMM	8 / 8 / 7 / 7	8 / 8 / 7 / 7	9 / 9 / 8 / 7
					l/s	138 / 130 / 120 / 112	138 / 130 / 120 / 112	157 / 148 / 138 / 120
			Heating	Turbo / High / Mid / Low	CMM	10 / 9 / 9 / 8	10 / 9 / 9 / 8	11 / 11 / 10 / 9
	l/s			165 / 157 / 148 / 138	165 / 157 / 148 / 138	183 / 175 / 165 / 148		
Fan Motor	Type			-	BLDC	BLDC	BLDC	
	Quantity			EA	1	1	1	

2. Specification

Première

System	Model Code	Indoor Unit		-	AR70H07C1AWNEU	AR70H09C1AWNEU	AR70H12C1AWNEU	
		Outdoor Unit		-	AR70H07C1AWXEU	AR70H09C1AWXEU	AR70H12C1AWXEU	
Indoor Unit	Fan Motor	Output		W	27	27	27	
	Drain	Drain Pipe	Diameter	-	Φ16.3, 550mm	Φ16.3, 550mm	Φ16.3, 550mm	
		Net Weight		kg	10.5	10.5	10.5	
	External Dimension	Shipping Weight		kg	12.5	12.5	12.5	
		Net Dimensions	W x H x D	mm	889 x 299 x 230	889 x 299 x 230	889 x 299 x 230	
		Shipping Dimensions	W x H x D	mm	950 x 320 x 375	950 x 320 x 375	950 x 320 x 375	
	Additional Accessories	Individual Control	Wireless Controller		-	Included	Included	Included
			Wired Controller		-	-	-	-
		Motion Detect Sensor		-	-	-	-	
		Easy Filter Plus		-	0	0	0	
Smart Function	WiFi	WiFi Embedded	-	0	0	0		
Outdoor Unit	Power Supply			Φ # V Hz	1 2 220-240 50	1 2 220-240 50	1 2 220-240 50	
	Performance	kW		-	2.0	2.5	3.5	
	Casing	Material	Body	-	EGI Steel Plate / PP	EGI Steel Plate / PP	EGI Steel Plate / PP	
		Type		-	F&T	F&T	F&T	
	Heat Exchanger	Material	Fin	-	Al	Al	Al	
			Tube	-	Cu	Cu	Cu	
		Fin Treatment		-	Hydrophile	Hydrophile	Hydrophile	
	Compressor	Model Name		-	KTN130D42UFR	KTN130D42UFR	KTN130D42UFR	
		Quantity		EA	1	1	1	
		Type		-	TWIN_ROTARY	TWIN_ROTARY	TWIN_ROTARY	
		Oil	Type	-	POE	POE	POE	
	Initial Charge		cc	350	350	350		
	Fan	Type		-	Propeller	Propeller	Propeller	
		Discharge direction		-	Horizontal	Horizontal	Horizontal	
		Quantity		EA	1	1	1	
		Air Flow Rate		CMM	45	45	45	
	l/s			750	750	750		
	Fan Motor	Type		-	BLDC	BLDC	BLDC	
		Quantity		EA	1	1	1	
		Output		W	45	45	45	
	Sound Level	Sound Pressure Level	Cooling	dB(A)	45	45	46	
		Sound Power Level	Cooling	dB(A)	59	59	62	
	External Dimension	Net Weight		kg	30.5	30.5	30.5	
		Shipping Weight		kg	32.5	32.5	32.5	
		Net Dimensions	W x H x D	mm	790 x 548 x 285	790 x 548 x 285	790 x 548 x 285	
		Shipping Dimensions	W x H x D	mm	913 x 622 x 371	913 x 622 x 371	913 x 622 x 371	
	Operating Temp. Range	Cooling	Min. ~ Max.	°C	-10 ~ 46	-10 ~ 46	-10 ~ 46	
Heating		Min. ~ Max.	°C	-15 ~ 24	-15 ~ 24	-15 ~ 24		

NOTE

- Specifications may be subject to change without prior notice.
- 1) Nominal cooling capacities are based on;
 - Indoor temperature: 27°C DB, 19°C WB
 - Outdoor temperature: 35°C DB, 24°C WB, Equivalent refrigerant piping: 5m, Level differences: 0 m
- 2) Nominal heating capacities are based on;
 - Indoor temperature: 20°C DB, 15°C WB
 - Outdoor temperature: 7°C DB, 6°C WB, Equivalent refrigerant piping: 5m, Level differences: 0 m
- 3) Sound pressure was acquired in an anechoic room. Thus actual noise level may be different depending on the installation conditions.
- 4) These products contain R32 which is fluorinated greenhouse gas.

2. Specification

Première

System	Model Code	Indoor Unit		-	AR70H15C1AWNEU	AR70H18C1AWNEU	AR70H24C1AWNEU	
		Outdoor Unit		-	AR70H15C1AWXEU	AR70H18C1AWXEU	AR70H24C1AWXEU	
	Mode				-	Heat Pump	Heat Pump	Heat Pump
	Performance	Capacity	Cooling	Min / Std. / Max	kW	1.1 / 4.3 / 5.0	1.6 / 5.0 / 6.7	1.4 / 6.5 / 7.6
					Btu/h	3,750 / 14,670 / 17,060	5,460 / 17,060 / 22,860	4,780 / 22,180 / 25,930
			Heating	Min / Std. / Max	kW	0.9 / 4.7 / 7.6	1.3 / 6.0 / 8.0	1.2 / 6.9 / 9.7
					Btu/h	2,900 / 16,040 / 25,930	4,440 / 20,470 / 27,300	4,100 / 23,540 / 33,100
	Power	Power Input	Cooling	Min / Std. / Max	kW	0.18 / 1.18 / 1.57	0.32 / 1.39 / 2.18	0.30 / 1.95 / 2.60
			Heating	Min / Std. / Max	kW	0.13 / 1.26 / 2.39	0.27 / 1.61 / 2.50	0.27 / 1.85 / 3.20
		Current Input	Cooling	Min / Std. / Max	A	1.50 / 5.20 / 6.90	2.00 / 6.40 / 10.00	2.00 / 8.80 / 11.50
			Heating	Min / Std. / Max	A	1.10 / 5.60 / 10.50	1.70 / 7.80 / 11.50	1.70 / 8.10 / 14.00
	Efficiency	Cooling	EER		W/W	3.64	3.60	3.33
			SEER		W/W	8.20	7.20	7.00
			SEER	Energy Grade	-	A++	A++	A++
			Pdesignc		kW	4.30	5.00	6.50
		Heating	COP		W/W	3.73	3.73	3.73
			SCOP	Warmer	W/W	5.60	5.30	5.30
				Average	W/W	4.60	4.10	4.30
				Warmer(Energy Grade)	-	A+++	A+++	A+++
				Average(Energy Grade)	-	A++	A+	A+
			Pdesignh	Average	kW	2.70	3.80	4.10
	Warmer	kW		1.50	2.20	2.20		
	Piping Connections	Liquid Pipe	Type		-	Flaring	Flaring	Flaring
			Diameter		mm	6.35	6.35	6.35
				in	1/4	1/4	1/4	
		Gas Pipe	Type		-	Flaring	Flaring	Flaring
Diameter			mm	9.52	12.7	15.88		
		in	3/8	1/2	5/8			
Heat Insulation				-	Both liquid and gas pipes	Both liquid and gas pipes	Both liquid and gas pipes	
Piping length (ODU-IDU)		Max.	m	20	30	30		
Level difference (ODU-IDU)		Max.	m	10	15	15		
Wiring Connection	Power Source Wire			mm ²	1.5	1.5	2.5	
	Transmiss on Cable	Min.		mm ²	0.75	0.75	0.75	
		Remark		-	F1,F2	F1,F2	F1,F2	
Refrigerant	Type			-	R32	R32	R32	
	Factory Charge			kg	1.0	1.3	1.3	
				tCO ₂ e	0.64	0.88	0.88	
Sound Level	Sound Pressure Level	Cooling	High / Silent	dB(A)	41 / 25	41 / 25	45 / 27	
	Sound Power Level	Cooling		dB(A)	58	58	62	
Indoor Unit	Power Supply			Φ # V Hz	1 2 220-240 50	1 2 220-240 50	1 2 220-240 50	
	Heat Exchanger	Type		-	F&T	F&T	F&T	
		Material	Fin		-	Al	Al	Al
			Tube		-	Cu	Cu	Cu
		Fin Treatment				-	Hydrophile	Hydrophile
	Fan	Type			-	Crossflow	Crossflow	Crossflow
		Quantity			EA	1	1	1
		Air Flow Rate	Cooling	Turbo / High / Mid / Low	CMM	13 / 12 / 9 / 7	14 / 13 / 12 / 10	17 / 15 / 13 / 10
					l/s	220 / 193 / 157 / 120	238 / 217 / 195 / 172	282 / 250 / 217 / 172
			Heating	Turbo / High / Mid / Low	CMM	13 / 12 / 9 / 7	14 / 13 / 12 / 10	18 / 16 / 14 / 11
					l/s	220 / 193 / 157 / 120	238 / 217 / 195 / 172	293 / 260 / 227 / 183
	Fan Motor	Type			-	BLDC	BLDC	BLDC
Quantity			EA	1	1	1		

2. Specification

Première

System	Model Code	Indoor Unit		-	AR70H15C1AWNEU	AR70H18C1AWNEU	AR70H24C1AWNEU	
		Outdoor Unit		-	AR70H15C1AWXEU	AR70H18C1AWXEU	AR70H24C1AWXEU	
Indoor Unit	Fan Motor	Output		W	27	27	27	
	Drain	Drain Pipe	Diameter	-	Φ16.3, 550mm	Φ16.3, 550mm	Φ16.3, 550mm	
	External Dimension	Net Weight		kg	10.5	13.3	13.3	
		Shipping Weight		kg	12.5	15.8	15.8	
		Net Dimensions	W x H x D	mm	889 x 299 x 230	1,055 x 299 x 230	1,055 x 299 x 230	
		Shipping Dimensions	W x H x D	mm	950 x 320 x 375	1,115 x 320 x 400	1,115 x 320 x 400	
	Additional Accessories	Individual Control	Wireless Controller		-	Included	Included	Included
			Wired Controller		-	-	-	-
		Motion Detect Sensor		-	-	-	-	
		Easy Filter Plus		-	0	0	0	
Smart Function	WiFi	WiFi Embedded		-	0	0	0	
Outdoor Unit	Power Supply			Φ # V Hz	1 2 220-240 50	1 2 220-240 50	1 2 220-240 50	
	Performance	kW		-	4.3	5.0	6.5	
	Casing	Material	Body		-	EGI Steel Plate / PP	EGI Steel Plate / PP	EGI Steel Plate / PP
		Type		-	F&T	F&T	F&T	
	Heat Exchanger	Material	Fin		-	Al	Al	Al
			Tube		-	Cu	Cu	Cu
		Fin Treatment		-	Hydrophile	Hydrophile	Hydrophile	
	Compressor	Model Name		-	KTN130D42UFR	KTN150D42UFZ	KTN150D42UFR	
		Quantity		EA	1	1	1	
		Type		-	TWIN_ROTARY	BLDC_ROTARY	BLDC_ROTARY	
		Oil	Type		-	POE	POE	POE
	Initial Charge		cc	350	450	450		
	Fan	Type		-	Propeller	Propeller	Propeller	
		Discharge direction		-	Horizontal	Horizontal	Horizontal	
		Quantity		EA	1	1	1	
		Air Flow Rate		CMM	45	50	50	
	l/s			750	833	833		
	Fan Motor	Type		-	BLDC	BLDC	BLDC	
		Quantity		EA	1	1	1	
		Output		W	45	45	125	
	Sound Level	Sound Pressure Level	Cooling		dB(A)	48	51	54
		Sound Power Level	Cooling		dB(A)	65	65	68
	External Dimension	Net Weight		kg	30.5	36.8	38.6	
Shipping Weight		kg	32.5	40.1	42.0			
Net Dimensions		W x H x D	mm	790 x 548 x 285	880 x 638 x 310	880 x 638 x 310		
Shipping Dimensions		W x H x D	mm	913 x 622 x 371	1,023 x 724 x 413	1,023 x 724 x 413		
Operating Temp. Range	Cooling	Min. ~ Max.	°C	-10 ~ 46	-10 ~ 46	-10 ~ 46		
	Heating	Min. ~ Max.	°C	-15 ~ 24	-15 ~ 24	-15 ~ 24		

NOTE

- Specifications may be subject to change without prior notice.
- 1) Nominal cooling capacities are based on;
 - Indoor temperature: 27°C DB, 19°C WB
 - Outdoor temperature: 35°C DB, 24°C WB, Equivalent refrigerant piping: 5m, Level differences: 0 m
- 2) Nominal heating capacities are based on;
 - Indoor temperature: 20°C DB, 15°C WB
 - Outdoor temperature: 7°C DB, 6°C WB, Equivalent refrigerant piping: 5m, Level differences: 0 m
- 3) Sound pressure was acquired in an anechoic room. Thus actual noise level may be different depending on the installation conditions.
- 4) These products contain R32 which is fluorinated greenhouse gas.

2. Specification

Première Black

System	Indoor Unit		Outdoor Unit		-	AR70H07C1ABNEU	AR70H09C1ABNEU	AR70H12C1ABNEU
	Outdoor Unit		Indoor Unit		-	AR70H07C1AWXEU	AR70H09C1AWXEU	AR70H12C1AWXEU
	Mode				-	Heat Pump	Heat Pump	Heat Pump
Performance	Capacity	Cooling	Min / Std. / Max	kW	1.0 / 2.0 / 3.2	1.0 / 2.5 / 3.7	1.0 / 3.5 / 4.6	
				Btu/h	3,280 / 6,820 / 10,920	3,280 / 8,530 / 12,630	3,410 / 11,940 / 15,700	
		Heating	Min / Std. / Max	kW	0.7 / 2.2 / 6.7	0.7 / 3.2 / 7.0	0.7 / 4.0 / 7.2	
				Btu/h	2,390 / 7,510 / 22,860	2,390 / 10,920 / 23,890	2,220 / 13,650 / 24,570	
Power	Power Input	Cooling	Min / Std. / Max	kW	0.17 / 0.43 / 0.84	0.17 / 0.57 / 0.96	0.18 / 0.90 / 1.40	
				Heating	kW	0.15 / 0.46 / 2.25	0.15 / 0.76 / 2.20	0.13 / 1.07 / 2.40
	Current Input	Cooling	Min / Std. / Max	A	1.50 / 2.30 / 3.70	1.50 / 3.00 / 4.30	1.50 / 4.00 / 6.10	
				Heating	A	1.30 / 2.30 / 9.80	1.30 / 3.40 / 10.00	1.20 / 4.70 / 10.50
Efficiency	Cooling	EER		W/W	4.65	4.39	3.89	
		SEER		W/W	9.00	8.80	8.60	
		SEER	Energy Grade	-	A+++	A+++	A+++	
		Pdesignc		kW	2.00	2.50	3.50	
	Heating	COP		W/W	4.78	4.21	3.74	
		SCOP	Warmer	W/W	5.70	5.70	5.70	
			Average	W/W	4.80	4.80	4.80	
			Warmer(Energy Grade)	-	A+++	A+++	A+++	
			Average(Energy Grade)	-	A++	A++	A++	
		Pdesignh	Average	kW	2.20	2.30	2.40	
Warmer	kW		1.30	1.30	1.30			
Piping Connections	Liquid Pipe	Type		-	Flaring	Flaring	Flaring	
		Diameter		mm	6.35	6.35	6.35	
			in	1/4	1/4	1/4		
	Gas Pipe	Type		-	Flaring	Flaring	Flaring	
		Diameter		mm	9.52	9.52	9.52	
			in	3/8	3/8	3/8		
	Heat Insulation				-	Both liquid and gas pipes	Both liquid and gas pipes	Both liquid and gas pipes
	Piping length (ODU-IDU)		Max.	m	20	20	20	
Level difference (ODU-IDU)		Max.	m	10	10	10		
Wiring Connection	Power Source Wire			mm ²	1.5	1.5	1.5	
	Transmiss on Cable	Min.		mm ²	0.75	0.75	0.75	
		Remark		-	F1,F2	F1,F2	F1,F2	
Refrigerant	Type			-	R32	R32	R32	
	Factory Charge			kg	1.0	1.0	1.0	
				tCO2e	0.64	0.64	0.64	
Sound Level	Sound Pressure Level	Cooling	High / Silent	dB(A)	37 / 16	38 / 16	40 / 16	
	Sound Power Level	Cooling		dB(A)	56	56	58	
Indoor Unit	Power Supply				Φ # V Hz	1 2 220-240 50	1 2 220-240 50	1 2 220-240 50
	Heat Exchanger	Type			-	F&T	F&T	F&T
		Material	Fin		-	Al	Al	Al
			Tube		-	Cu	Cu	Cu
		Fin Treatment				-	Hydrophile	Hydrophile
	Fan	Type			-	Crossflow	Crossflow	Crossflow
		Quantity			EA	1	1	1
		Air Flow Rate	Cooling	Turbo / High / Mid / Low	CMM	8 / 8 / 7 / 7	8 / 8 / 7 / 7	9 / 9 / 8 / 7
					l/s	138 / 130 / 120 / 112	138 / 130 / 120 / 112	157 / 148 / 138 / 120
			Heating	Turbo / High / Mid / Low	CMM	10 / 9 / 9 / 8	10 / 9 / 9 / 8	11 / 11 / 10 / 9
l/s	165 / 157 / 148 / 138				165 / 157 / 148 / 138	183 / 175 / 165 / 148		
Fan Motor	Type			-	BLDC	BLDC	BLDC	
	Quantity			EA	1	1	1	

2. Specification

Première Black

System	Model Code	Indoor Unit		-	AR70H07C1ABNEU	AR70H09C1ABNEU	AR70H12C1ABNEU	
		Outdoor Unit		-	AR70H07C1AWXEU	AR70H09C1AWXEU	AR70H12C1AWXEU	
Indoor Unit	Fan Motor	Output		W	27	27	27	
	Drain	Drain Pipe	Diameter	-	Φ16.3, 550mm	Φ16.3, 550mm	Φ16.3, 550mm	
		Net Weight		kg	10.5	10.5	10.5	
	External Dimension	Shipping Weight		kg	12.5	12.5	12.5	
		Net Dimensions	W x H x D	mm	889 x 299 x 230	889 x 299 x 230	889 x 299 x 230	
		Shipping Dimensions	W x H x D	mm	950 x 320 x 375	950 x 320 x 375	950 x 320 x 375	
	Additional Accessories	Individual Control	Wireless Controller		-	Included	Included	Included
			Wired Controller		-	-	-	-
		Motion Detect Sensor		-	-	-	-	
		Easy Filter Plus		-	0	0	0	
Smart Function	WiFi	WiFi Embedded	-	0	0	0		
Outdoor Unit	Power Supply			Φ # V Hz	1 2 220-240 50	1 2 220-240 50	1 2 220-240 50	
	Performance	kW		-	2.0	2.5	3.5	
	Casing	Material	Body	-	EGI Steel Plate / PP	EGI Steel Plate / PP	EGI Steel Plate / PP	
		Type		-	F&T	F&T	F&T	
	Heat Exchanger	Material	Fin	-	Al	Al	Al	
			Tube	-	Cu	Cu	Cu	
		Fin Treatment		-	Hydrophile	Hydrophile	Hydrophile	
	Compressor	Model Name		-	KTN130D42UFR	KTN130D42UFR	KTN130D42UFR	
		Quantity		EA	1	1	1	
		Type		-	TWIN_ROTARY	TWIN_ROTARY	TWIN_ROTARY	
		Oil	Type	-	POE	POE	POE	
	Initial Charge		cc	350	350	350		
	Fan	Type		-	Propeller	Propeller	Propeller	
		Discharge direction		-	Horizontal	Horizontal	Horizontal	
		Quantity		EA	1	1	1	
		Air Flow Rate		CMM	45	45	45	
	l/s			750	750	750		
	Fan Motor	Type		-	BLDC	BLDC	BLDC	
		Quantity		EA	1	1	1	
		Output		W	45	45	45	
	Sound Level	Sound Pressure Level	Cooling	dB(A)	45	45	46	
		Sound Power Level	Cooling	dB(A)	59	59	62	
	External Dimension	Net Weight		kg	30.5	30.5	30.5	
Shipping Weight		kg	32.5	32.5	32.5			
Net Dimensions		W x H x D	mm	790 x 548 x 285	790 x 548 x 285	790 x 548 x 285		
Shipping Dimensions		W x H x D	mm	913 x 622 x 371	913 x 622 x 371	913 x 622 x 371		
Operating Temp. Range	Cooling	Min. ~ Max.	°C	-10 ~ 46	-10 ~ 46	-10 ~ 46		
	Heating	Min. ~ Max.	°C	-15 ~ 24	-15 ~ 24	-15 ~ 24		

NOTE

- Specifications may be subject to change without prior notice.
- 1) Nominal cooling capacities are based on;
 - Indoor temperature: 27°C DB, 19°C WB
 - Outdoor temperature: 35°C DB, 24°C WB, Equivalent refrigerant piping: 5m, Level differences: 0 m
- 2) Nominal heating capacities are based on;
 - Indoor temperature: 20°C DB, 15°C WB
 - Outdoor temperature: 7°C DB, 6°C WB, Equivalent refrigerant piping: 5m, Level differences: 0 m
- 3) Sound pressure was acquired in an anechoic room. Thus actual noise level may be different depending on the installation conditions.
- 4) These products contain R32 which is fluorinated greenhouse gas.

3. Summary Table

Indoor units

Performance Characteristics

Model Code		Capacity		Fan speed	Air flow rate		Sound Pressure Level dBA	Sound Power Level dBA
		Cooling	Heating		Cooling	Heating		
		kW	kW		CMM	CMM		
AR70H09CAAWNEU	Max.	4.00	7.10	High	9.10	11.10	38	56
	Std.	2.50	3.20	Mid	8.10	10.10	-	-
	Min.	1.00	0.75	Low	6.60	8.60	-	-
AR70H12CAAWNEU	Max.	4.80	7.30	High	9.60	10.60	40	58
	Std.	3.50	4.00	Mid	8.10	9.10	-	-
	Min.	1.00	0.75	Low	6.60	7.60	-	-
AR70H09CAABNEU	Max.	4.00	7.10	High	9.10	11.10	38	56
	Std.	2.50	3.20	Mid	8.10	10.10	-	-
	Min.	1.00	0.75	Low	6.60	8.60	-	-
AR70H12CAABNEU	Max.	4.80	7.30	High	9.60	10.60	40	58
	Std.	3.50	4.00	Mid	8.10	9.10	-	-
	Min.	1.00	0.75	Low	6.60	7.60	-	-
AR70H07C1AWNEU	Max.	3.20	6.70	High	7.80	9.40	37	56
	Std.	2.00	2.20	Mid	7.20	8.90	-	-
	Min.	0.96	0.70	Low	6.70	8.30	-	-
AR70H09C1AWNEU	Max.	3.70	7.00	High	7.80	9.40	38	56
	Std.	2.50	3.20	Mid	7.20	8.90	-	-
	Min.	0.96	0.70	Low	6.70	8.30	-	-
AR70H12C1AWNEU	Max.	4.60	7.20	High	8.90	10.50	40	58
	Std.	3.50	4.00	Mid	8.30	9.90	-	-
	Min.	1.00	0.65	Low	7.20	8.90	-	-
AR70H15C1AWNEU	Max.	5.00	7.60	High	11.60	11.60	41	58
	Std.	4.30	4.70	Mid	9.40	9.40	-	-
	Min.	1.10	0.85	Low	7.20	7.20	-	-
AR70H18C1AWNEU	Max.	6.70	8.00	High	13.00	13.00	41	58
	Std.	5.00	6.00	Mid	11.70	11.70	-	-
	Min.	1.60	1.30	Low	10.30	10.30	-	-
AR70H24C1AWNEU	Max.	7.60	9.70	High	15.00	15.60	45	62
	Std.	6.50	6.90	Mid	13.00	13.60	-	-
	Min.	1.40	1.20	Low	10.30	11.00	-	-
AR70H07C1ABNEU	Max.	3.20	6.70	High	7.80	9.40	37	56
	Std.	2.00	2.20	Mid	7.20	8.90	-	-
	Min.	0.96	0.70	Low	6.70	8.30	-	-
AR70H09C1ABNEU	Max.	3.70	7.00	High	7.80	9.40	38	56
	Std.	2.50	3.20	Mid	7.20	8.90	-	-
	Min.	0.96	0.70	Low	6.70	8.30	-	-
AR70H12C1ABNEU	Max.	4.60	7.20	High	8.90	10.50	40	58
	Std.	3.50	4.00	Mid	8.30	9.90	-	-
	Min.	1.00	0.65	Low	7.20	8.90	-	-

NOTE

- Sound data is based on cooling operation.

3. Summary Table

Outdoor Unit

Performance Characteristics

Capacity kW	Model Code	Air flow rate CMM	Sound Pressure Level	Sound Power Level dBA
			Cooling dBA	
2.00	AR70H07C1AWXEU	45.00	45	59
2.50	AR70H09C1AWXEU	45.00	45	59
2.50	AR70H09CAAWXEU	45.00	45	59
3.50	AR70H12C1AWXEU	45.00	46	62
3.50	AR70H12CAAWXEU	45.00	46	62
4.30	AR70H15C1AWXEU	45.00	48	65
5.00	AR70H18C1AWXEU	50.00	51	65
6.50	AR70H24C1AWXEU	50.00	54	68

 **NOTE**

- Sound data is based on cooling operation.
-

4. Capacity Table

Première Plus

AR70H09CAAWNEU + AR70H09CAAWXEU

Cooling

TC : Total Capacity, SHC : Sensible Heat Capacity, PI : Power Input

Outdoor Temperature	Indoor Temperature (°C, DB / WB)																										
	18.0/12.0			20.0/14.0			22.0/16.0			25.0/18.0			27.0/19.0			28.0/20.0			30.0/22.0			32.0/24.0					
	DB	TC	SHC	PI	TC	SHC	PI	TC	SHC	PI	TC	SHC	PI	TC	SHC	PI	TC	SHC	PI	TC	SHC	PI	TC	SHC	PI		
°C	kW	kW	kW	kW	kW	kW	kW	kW	kW	kW	kW	kW	kW	kW	kW	kW	kW	kW	kW	kW	kW	kW	kW	kW	kW	kW	kW
-10.0	2.6	2.4	0.69	2.8	2.5	0.69	3.0	2.6	0.72	3.2	2.7	0.74	3.3	2.8	0.79	3.5	2.8	0.77	3.7	2.9	0.79	4.0	2.9	0.78			
0	2.7	2.6	0.64	3.0	2.6	0.65	3.2	2.8	0.68	3.5	2.9	0.70	3.6	3.1	0.74	3.8	3.0	0.72	4.0	3.1	0.74	4.2	3.1	0.74			
10.0	2.9	2.7	0.58	3.1	2.7	0.58	3.3	2.8	0.60	3.6	2.9	0.63	3.8	3.1	0.66	3.9	3.0	0.65	4.2	3.1	0.66	4.4	3.1	0.66			
20.0	3.0	2.7	0.54	3.2	2.8	0.55	3.4	2.9	0.57	3.7	3.0	0.59	3.9	3.2	0.62	4.0	3.1	0.61	4.2	3.1	0.63	4.5	3.1	0.63			
25.0	3.0	2.7	0.68	3.2	2.8	0.69	3.4	2.9	0.71	3.7	3.0	0.73	3.9	3.2	0.75	4.1	3.1	0.75	4.3	3.2	0.76	4.5	3.2	0.77			
30.0	3.0	2.7	0.85	3.3	2.8	0.86	3.5	2.9	0.88	3.8	3.0	0.90	4.0	3.2	0.92	4.1	3.1	0.92	4.3	3.2	0.93	4.6	3.2	0.94			
35.0	3.0	2.7	1.02	3.3	2.8	1.03	3.5	2.9	1.04	3.8	3.0	1.06	2.5	2.0	0.52	4.2	3.1	1.08	4.4	3.2	1.10	4.7	3.2	1.11			
40.0	2.8	2.6	1.12	3.1	2.6	1.13	3.3	2.7	1.15	3.6	2.8	1.17	3.7	3.0	1.18	3.9	2.9	1.19	4.1	3.0	1.21	4.4	3.0	1.22			
43.0	2.7	2.5	1.18	3.0	2.5	1.19	3.1	2.6	1.21	3.5	2.7	1.23	3.6	2.9	1.25	3.8	2.8	1.26	4.0	2.9	1.27	4.2	2.9	1.29			
46.0	2.6	2.4	1.24	2.8	2.4	1.25	3.0	2.5	1.27	3.3	2.6	1.30	3.5	2.8	1.31	3.6	2.7	1.32	3.8	2.8	1.34	4.1	2.8	1.35			

Heating

TC : Total Capacity, PI : Power Input

Outdoor Temperature	Indoor Temperature (°C, DB)											
	16.0		18.0		20.0		21.0		22.0		24.0	
	DB	TC	PI	TC	PI	TC	PI	TC	PI	TC	PI	TC
°C	kW	kW	kW	kW	kW	kW	kW	kW	kW	kW	kW	kW
-15.0	3.8	1.56	3.7	1.59	3.6	1.62	3.6	1.62	3.6	1.63	3.5	1.66
-10.0	4.3	1.71	4.3	1.74	4.2	1.78	4.2	1.79	4.1	1.79	4.1	1.83
-5.0	4.9	1.90	4.8	1.94	4.8	1.98	4.7	1.99	4.7	2.01	4.6	2.04
0	4.7	1.55	4.6	1.58	4.5	1.61	4.5	1.62	4.5	1.63	4.4	1.66
2.0	4.8	1.45	4.7	1.48	4.6	1.51	4.6	1.52	4.5	1.53	4.4	1.56
5.0	4.9	1.31	4.8	1.33	4.7	1.36	4.7	1.37	4.7	1.38	4.6	1.41
7.0	5.0	1.21	4.9	1.23	4.8	1.26	4.8	1.27	4.7	1.28	4.6	1.30
10.0	4.9	1.15	4.8	1.17	4.7	1.20	4.7	1.21	4.7	1.21	4.6	1.24
15.0	4.9	1.09	4.8	1.11	4.7	1.13	4.7	1.14	4.7	1.15	4.6	1.17
20.0	5.1	1.15	5.0	1.18	4.9	1.20	4.9	1.21	4.8	1.22	4.7	1.24
24.0	5.2	1.21	5.1	1.23	5.0	1.26	5.0	1.26	5.0	1.27	4.9	1.30

NOTE

- The performance table shows the average value of each conditions.

4. Capacity Table

Première Plus

AR70H12CAAWNEU + AR70H12CAAWXEU

Cooling

TC : Total Capacity, SHC : Sensible Heat Capacity, PI : Power Input

Outdoor Temperature	Indoor Temperature (°C, DB / WB)																									
	18.0/12.0			20.0/14.0			22.0/16.0			25.0/18.0			27.0/19.0			28.0/20.0			30.0/22.0			32.0/24.0				
	DB	TC	SHC	PI	TC	SHC	PI	TC	SHC	PI	TC	SHC	PI	TC	SHC	PI	TC	SHC	PI	TC	SHC	PI	TC	SHC	PI	
°C	kW	kW	kW	kW	kW	kW	kW	kW	kW	kW	kW	kW	kW	kW	kW	kW	kW	kW	kW	kW	kW	kW	kW	kW	kW	kW
-10.0	2.8	2.5	0.80	3.1	2.5	0.80	3.3	2.6	0.84	3.6	2.8	0.87	3.7	2.9	0.92	3.9	2.9	0.90	4.1	2.9	0.91	4.4	3.0	0.91		
0	3.0	2.7	0.74	3.3	2.7	0.74	3.5	2.8	0.77	3.8	2.9	0.80	3.9	3.1	0.85	4.2	3.0	0.83	4.4	3.1	0.84	4.7	3.1	0.84		
10.0	3.2	2.7	0.68	3.4	2.8	0.69	3.6	2.9	0.72	4.0	3.0	0.74	4.1	3.2	0.79	4.3	3.1	0.77	4.5	3.2	0.79	4.8	3.2	0.79		
20.0	3.2	2.7	0.63	3.4	2.7	0.64	3.6	2.8	0.66	4.0	2.9	0.68	4.1	3.1	0.72	4.3	3.0	0.71	4.5	3.1	0.73	4.8	3.1	0.73		
25.0	3.3	2.8	0.82	3.5	2.8	0.83	3.7	2.9	0.86	4.1	3.0	0.88	4.3	3.2	0.91	4.4	3.1	0.91	4.7	3.2	0.92	4.9	3.2	0.93		
30.0	3.4	2.9	1.07	3.7	2.9	1.09	3.9	3.0	1.11	4.3	3.1	1.13	4.5	3.3	1.16	4.7	3.2	1.16	4.9	3.3	1.18	5.2	3.3	1.19		
35.0	3.5	3.0	1.33	3.8	3.0	1.34	4.1	3.1	1.36	4.5	3.2	1.39	3.5	2.8	0.85	4.9	3.4	1.41	5.2	3.5	1.43	5.5	3.5	1.45		
40.0	3.2	2.7	1.40	3.5	2.7	1.42	3.7	2.8	1.44	4.1	3.0	1.46	4.3	3.2	1.48	4.5	3.1	1.49	4.7	3.2	1.51	5.0	3.2	1.53		
43.0	3.0	2.5	1.44	3.3	2.6	1.46	3.5	2.7	1.48	3.9	2.8	1.51	4.0	3.0	1.53	4.2	2.9	1.54	4.4	3.0	1.56	4.7	3.0	1.57		
46.0	2.9	2.4	1.49	3.1	2.4	1.51	3.3	2.5	1.53	3.6	2.6	1.56	3.8	2.8	1.58	4.0	2.7	1.58	4.2	2.8	1.60	4.4	2.8	1.62		

Heating

TC : Total Capacity, PI : Power Input

Outdoor Temperature	Indoor Temperature (°C, DB)											
	16.0		18.0		20.0		21.0		22.0		24.0	
	DB	TC	PI	TC	PI	TC	PI	TC	PI	TC	PI	TC
°C	kW	kW	kW	kW	kW	kW	kW	kW	kW	kW	kW	kW
-15.0	4.4	1.90	4.3	1.94	4.2	1.98	4.2	1.99	4.2	1.99	4.1	2.03
-10.0	5.1	2.12	5.0	2.16	4.8	2.21	4.8	2.22	4.8	2.23	4.7	2.27
-5.0	5.4	2.16	5.3	2.21	5.2	2.26	5.2	2.27	5.2	2.29	5.1	2.33
0	5.5	1.95	5.4	1.99	5.3	2.03	5.3	2.04	5.3	2.06	5.2	2.10
2.0	5.5	1.78	5.4	1.81	5.3	1.85	5.2	1.86	5.2	1.88	5.1	1.91
5.0	5.3	1.52	5.3	1.55	5.1	1.58	5.1	1.59	5.1	1.60	5.0	1.64
7.0	5.3	1.35	5.2	1.37	4.0	0.94	5.0	1.41	5.0	1.42	4.9	1.45
10.0	5.2	1.24	5.1	1.26	5.0	1.29	5.0	1.30	5.0	1.31	4.9	1.33
15.0	5.2	1.09	5.1	1.11	5.0	1.14	5.0	1.14	5.0	1.15	4.9	1.17
20.0	5.4	1.09	5.3	1.11	5.2	1.14	5.2	1.14	5.2	1.15	5.1	1.17
24.0	5.6	1.09	5.5	1.11	5.4	1.13	5.4	1.14	5.3	1.15	5.2	1.17

NOTE

- The performance table shows the average value of each conditions.

4. Capacity Table

Première Plus Black

AR70H09CAABNEU + AR70H09CAAWXEU

Cooling

TC : Total Capacity, SHC : Sensible Heat Capacity, PI : Power Input

Outdoor Temperature	Indoor Temperature (°C, DB / WB)																										
	18.0/12.0			20.0/14.0			22.0/16.0			25.0/18.0			27.0/19.0			28.0/20.0			30.0/22.0			32.0/24.0					
DB	TC	SHC	PI	TC	SHC	PI	TC	SHC	PI	TC	SHC	PI	TC	SHC	PI	TC	SHC	PI	TC	SHC	PI	TC	SHC	PI	TC	SHC	PI
°C	kW	kW	kW	kW	kW	kW	kW	kW	kW	kW	kW	kW	kW	kW	kW	kW	kW	kW	kW	kW	kW	kW	kW	kW	kW	kW	kW
-10.0	2.6	2.4	0.69	2.8	2.5	0.69	3.0	2.6	0.72	3.2	2.7	0.74	3.3	2.8	0.79	3.5	2.8	0.77	3.7	2.9	0.79	4.0	2.9	0.78			
0	2.7	2.6	0.64	3.0	2.6	0.65	3.2	2.8	0.68	3.5	2.9	0.70	3.6	3.1	0.74	3.8	3.0	0.72	4.0	3.1	0.74	4.2	3.1	0.74			
10.0	2.9	2.7	0.58	3.1	2.7	0.58	3.3	2.8	0.60	3.6	2.9	0.63	3.8	3.1	0.66	3.9	3.0	0.65	4.2	3.1	0.66	4.4	3.1	0.66			
20.0	3.0	2.7	0.54	3.2	2.8	0.55	3.4	2.9	0.57	3.7	3.0	0.59	3.9	3.2	0.62	4.0	3.1	0.61	4.2	3.1	0.63	4.5	3.1	0.63			
25.0	3.0	2.7	0.68	3.2	2.8	0.69	3.4	2.9	0.71	3.7	3.0	0.73	3.9	3.2	0.75	4.1	3.1	0.75	4.3	3.2	0.76	4.5	3.2	0.77			
30.0	3.0	2.7	0.85	3.3	2.8	0.86	3.5	2.9	0.88	3.8	3.0	0.90	4.0	3.2	0.92	4.1	3.1	0.92	4.3	3.2	0.93	4.6	3.2	0.94			
35.0	3.0	2.7	1.02	3.3	2.8	1.03	3.5	2.9	1.04	3.8	3.0	1.06	2.5	2.0	0.52	4.2	3.1	1.08	4.4	3.2	1.10	4.7	3.2	1.11			
40.0	2.8	2.6	1.12	3.1	2.6	1.13	3.3	2.7	1.15	3.6	2.8	1.17	3.7	3.0	1.18	3.9	2.9	1.19	4.1	3.0	1.21	4.4	3.0	1.22			
43.0	2.7	2.5	1.18	3.0	2.5	1.19	3.1	2.6	1.21	3.5	2.7	1.23	3.6	2.9	1.25	3.8	2.8	1.26	4.0	2.9	1.27	4.2	2.9	1.29			
46.0	2.6	2.4	1.24	2.8	2.4	1.25	3.0	2.5	1.27	3.3	2.6	1.30	3.5	2.8	1.31	3.6	2.7	1.32	3.8	2.8	1.34	4.1	2.8	1.35			

Heating

TC : Total Capacity, PI : Power Input

Outdoor Temperature	Indoor Temperature (°C, DB)											
	16.0		18.0		20.0		21.0		22.0		24.0	
DB	TC	PI	TC	PI	TC	PI	TC	PI	TC	PI	TC	PI
°C	kW	kW	kW	kW	kW	kW	kW	kW	kW	kW	kW	kW
-15.0	3.8	1.56	3.7	1.59	3.6	1.62	3.6	1.62	3.6	1.63	3.5	1.66
-10.0	4.3	1.71	4.3	1.74	4.2	1.78	4.2	1.79	4.1	1.79	4.1	1.83
-5.0	4.9	1.90	4.8	1.94	4.8	1.98	4.7	1.99	4.7	2.01	4.6	2.04
0	4.7	1.55	4.6	1.58	4.5	1.61	4.5	1.62	4.5	1.63	4.4	1.66
2.0	4.8	1.45	4.7	1.48	4.6	1.51	4.6	1.52	4.5	1.53	4.4	1.56
5.0	4.9	1.31	4.8	1.33	4.7	1.36	4.7	1.37	4.7	1.38	4.6	1.41
7.0	5.0	1.21	4.9	1.23	3.2	0.68	4.8	1.27	4.7	1.28	4.6	1.30
10.0	4.9	1.15	4.8	1.17	4.7	1.20	4.7	1.21	4.7	1.21	4.6	1.24
15.0	4.9	1.09	4.8	1.11	4.7	1.13	4.7	1.14	4.7	1.15	4.6	1.17
20.0	5.1	1.15	5.0	1.18	4.9	1.20	4.9	1.21	4.8	1.22	4.7	1.24
24.0	5.2	1.21	5.1	1.23	5.0	1.26	5.0	1.26	5.0	1.27	4.9	1.30

NOTE

- The performance table shows the average value of each conditions.

4. Capacity Table

Première Plus Black

AR70H12CAABNEU + AR70H12CAAWXEU

Cooling

TC : Total Capacity, SHC : Sensible Heat Capacity, PI : Power Input

Outdoor Temperature	Indoor Temperature (°C, DB / WB)																										
	18.0/12.0			20.0/14.0			22.0/16.0			25.0/18.0			27.0/19.0			28.0/20.0			30.0/22.0			32.0/24.0					
DB	TC	SHC	PI	TC	SHC	PI	TC	SHC	PI	TC	SHC	PI	TC	SHC	PI	TC	SHC	PI	TC	SHC	PI	TC	SHC	PI	TC	SHC	PI
°C	kW	kW	kW	kW	kW	kW	kW	kW	kW	kW	kW	kW	kW	kW	kW	kW	kW	kW	kW	kW	kW	kW	kW	kW	kW	kW	kW
-10.0	2.8	2.5	0.80	3.1	2.5	0.80	3.3	2.6	0.84	3.6	2.8	0.87	3.7	2.9	0.92	3.9	2.9	0.90	4.1	2.9	0.91	4.4	3.0	0.91			
0	3.0	2.7	0.74	3.3	2.7	0.74	3.5	2.8	0.77	3.8	2.9	0.80	3.9	3.1	0.85	4.2	3.0	0.83	4.4	3.1	0.84	4.7	3.1	0.84			
10.0	3.2	2.7	0.68	3.4	2.8	0.69	3.6	2.9	0.72	4.0	3.0	0.74	4.1	3.2	0.79	4.3	3.1	0.77	4.5	3.2	0.79	4.8	3.2	0.79			
20.0	3.2	2.7	0.63	3.4	2.7	0.64	3.6	2.8	0.66	4.0	2.9	0.68	4.1	3.1	0.72	4.3	3.0	0.71	4.5	3.1	0.73	4.8	3.1	0.73			
25.0	3.3	2.8	0.82	3.5	2.8	0.83	3.7	2.9	0.86	4.1	3.0	0.88	4.3	3.2	0.91	4.4	3.1	0.91	4.7	3.2	0.92	4.9	3.2	0.93			
30.0	3.4	2.9	1.07	3.7	2.9	1.09	3.9	3.0	1.11	4.3	3.1	1.13	4.5	3.3	1.16	4.7	3.2	1.16	4.9	3.3	1.18	5.2	3.3	1.19			
35.0	3.5	3.0	1.33	3.8	3.0	1.34	4.1	3.1	1.36	4.5	3.2	1.39	3.5	2.8	0.85	4.9	3.4	1.41	5.2	3.5	1.43	5.5	3.5	1.45			
40.0	3.2	2.7	1.40	3.5	2.7	1.42	3.7	2.8	1.44	4.1	3.0	1.46	4.3	3.2	1.48	4.5	3.1	1.49	4.7	3.2	1.51	5.0	3.2	1.53			
43.0	3.0	2.5	1.44	3.3	2.6	1.46	3.5	2.7	1.48	3.9	2.8	1.51	4.0	3.0	1.53	4.2	2.9	1.54	4.4	3.0	1.56	4.7	3.0	1.57			
46.0	2.9	2.4	1.49	3.1	2.4	1.51	3.3	2.5	1.53	3.6	2.6	1.56	3.8	2.8	1.58	4.0	2.7	1.58	4.2	2.8	1.60	4.4	2.8	1.62			

Heating

TC : Total Capacity, PI : Power Input

Outdoor Temperature	Indoor Temperature (°C, DB)											
	16.0		18.0		20.0		21.0		22.0		24.0	
DB	TC	PI	TC	PI	TC	PI	TC	PI	TC	PI	TC	PI
°C	kW	kW	kW	kW	kW	kW	kW	kW	kW	kW	kW	kW
-15.0	4.4	1.90	4.3	1.94	4.2	1.98	4.2	1.99	4.2	1.99	4.1	2.03
-10.0	5.1	2.12	5.0	2.16	4.8	2.21	4.8	2.22	4.8	2.23	4.7	2.27
-5.0	5.4	2.16	5.3	2.21	5.2	2.26	5.2	2.27	5.2	2.29	5.1	2.33
0	5.5	1.95	5.4	1.99	5.3	2.03	5.3	2.04	5.3	2.06	5.2	2.10
2.0	5.5	1.78	5.4	1.81	5.3	1.85	5.2	1.86	5.2	1.88	5.1	1.91
5.0	5.3	1.52	5.3	1.55	5.1	1.58	5.1	1.59	5.1	1.60	5.0	1.64
7.0	5.3	1.35	5.2	1.37	4.0	0.94	5.0	1.41	5.0	1.42	4.9	1.45
10.0	5.2	1.24	5.1	1.26	5.0	1.29	5.0	1.30	5.0	1.31	4.9	1.33
15.0	5.2	1.09	5.1	1.11	5.0	1.14	5.0	1.14	5.0	1.15	4.9	1.17
20.0	5.4	1.09	5.3	1.11	5.2	1.14	5.2	1.14	5.2	1.15	5.1	1.17
24.0	5.6	1.09	5.5	1.11	5.4	1.13	5.4	1.14	5.3	1.15	5.2	1.17

NOTE

- The performance table shows the average value of each conditions.

4. Capacity Table

Première

AR70H07C1AWNEU + AR70H07C1AWXEU

Cooling

TC : Total Capacity, SHC : Sensible Heat Capacity, PI : Power Input

Outdoor Temperature	Indoor Temperature (°C, DB / WB)																										
	18.0/12.0			20.0/14.0			22.0/16.0			25.0/18.0			27.0/19.0			28.0/20.0			30.0/22.0			32.0/24.0					
	DB	TC	SHC	PI	TC	SHC	PI	TC	SHC	PI	TC	SHC	PI	TC	SHC	PI	TC	SHC	PI	TC	SHC	PI	TC	SHC	PI		
°C	kW	kW	kW	kW	kW	kW	kW	kW	kW	kW	kW	kW	kW	kW	kW	kW	kW	kW	kW	kW	kW	kW	kW	kW	kW	kW	kW
-10.0	2.1	2.0	0.48	2.3	2.0	0.48	2.4	2.1	0.50	2.7	2.2	0.52	2.8	2.4	0.55	2.9	2.3	0.54	3.1	2.4	0.55	3.3	2.4	0.55			
0	2.4	2.3	0.41	2.6	2.3	0.41	2.7	2.4	0.43	3.0	2.5	0.44	3.1	2.6	0.47	3.3	2.6	0.46	3.4	2.7	0.47	3.7	2.7	0.46			
10.0	2.3	2.2	0.42	2.5	2.2	0.43	2.7	2.3	0.45	2.9	2.4	0.46	3.0	2.5	0.49	3.2	2.4	0.48	3.3	2.5	0.49	3.5	2.5	0.49			
20.0	2.4	2.2	0.39	2.6	2.3	0.40	2.8	2.3	0.41	3.0	2.4	0.43	3.2	2.6	0.45	3.3	2.5	0.44	3.5	2.6	0.46	3.7	2.6	0.46			
25.0	2.5	2.3	0.50	2.7	2.3	0.51	2.8	2.4	0.52	3.1	2.5	0.54	3.2	2.6	0.56	3.4	2.6	0.55	3.5	2.6	0.56	3.8	2.6	0.57			
30.0	2.5	2.3	0.65	2.7	2.3	0.66	2.9	2.4	0.67	3.2	2.5	0.69	3.3	2.6	0.70	3.4	2.6	0.70	3.6	2.6	0.71	3.8	2.6	0.72			
35.0	2.5	2.3	0.80	2.7	2.3	0.81	2.9	2.4	0.82	3.2	2.5	0.84	2.0	1.6	0.43	3.5	2.6	0.85	3.7	2.7	0.86	3.9	2.7	0.87			
40.0	2.3	2.1	0.89	2.5	2.1	0.90	2.7	2.2	0.91	3.0	2.3	0.93	3.1	2.5	0.94	3.2	2.4	0.94	3.4	2.5	0.96	3.6	2.5	0.97			
43.0	2.2	2.0	0.94	2.4	2.0	0.95	2.5	2.1	0.96	2.8	2.2	0.98	2.9	2.3	0.99	3.1	2.3	1.00	3.2	2.3	1.01	3.4	2.3	1.02			
46.0	2.1	1.9	0.99	2.3	1.9	1.00	2.4	2.0	1.01	2.7	2.1	1.03	2.8	2.2	1.05	2.9	2.2	1.05	3.1	2.2	1.07	3.3	2.2	1.08			

Heating

TC : Total Capacity, PI : Power Input

Outdoor Temperature	Indoor Temperature (°C, DB)											
	16.0		18.0		20.0		21.0		22.0		24.0	
	DB	TC	PI	TC	PI	TC	PI	TC	PI	TC	PI	TC
°C	kW	kW	kW	kW	kW	kW	kW	kW	kW	kW	kW	kW
-15.0	3.6	1.67	3.5	1.70	3.5	1.73	3.5	1.74	3.4	1.75	3.4	1.78
-10.0	4.2	1.86	4.1	1.90	4.0	1.94	4.0	1.95	4.0	1.95	3.9	1.99
-5.0	4.3	1.72	4.2	1.75	4.1	1.79	4.1	1.80	4.1	1.81	4.0	1.85
0	4.4	1.58	4.4	1.61	4.3	1.64	4.3	1.65	4.2	1.67	4.1	1.70
2.0	4.4	1.50	4.3	1.53	4.2	1.56	4.2	1.57	4.2	1.58	4.1	1.61
5.0	4.3	1.38	4.3	1.41	4.2	1.44	4.2	1.45	4.1	1.46	4.1	1.49
7.0	4.3	1.30	4.2	1.33	4.2	1.36	4.1	1.36	4.1	1.37	4.0	1.40
10.0	4.4	1.28	4.3	1.30	4.2	1.33	4.2	1.34	4.2	1.35	4.1	1.38
15.0	4.6	1.24	4.5	1.26	4.4	1.29	4.4	1.30	4.3	1.31	4.3	1.33
20.0	4.7	1.20	4.6	1.22	4.5	1.25	4.5	1.26	4.5	1.26	4.4	1.29
24.0	4.8	1.17	4.7	1.19	4.6	1.21	4.6	1.22	4.6	1.23	4.5	1.26

NOTE

- The performance table shows the average value of each conditions.

4. Capacity Table

Première

AR70H09C1AWNEU + AR70H09C1AWXEU

Cooling

TC : Total Capacity, SHC : Sensible Heat Capacity, PI : Power Input

Outdoor Temperature	Indoor Temperature (°C, DB / WB)																										
	18.0/12.0			20.0/14.0			22.0/16.0			25.0/18.0			27.0/19.0			28.0/20.0			30.0/22.0			32.0/24.0					
DB	TC	SHC	PI	TC	SHC	PI	TC	SHC	PI	TC	SHC	PI	TC	SHC	PI	TC	SHC	PI	TC	SHC	PI	TC	SHC	PI	TC	SHC	PI
°C	kW	kW	kW	kW	kW	kW	kW	kW	kW	kW	kW	kW	kW	kW	kW	kW	kW	kW	kW	kW	kW	kW	kW	kW	kW	kW	kW
-10.0	2.6	2.5	0.68	2.9	2.5	0.68	3.0	2.7	0.71	3.3	2.8	0.73	3.4	2.9	0.78	3.6	2.9	0.76	3.8	2.9	0.78	4.1	3.0	0.77			
0	2.8	2.6	0.62	3.0	2.7	0.62	3.2	2.8	0.65	3.5	2.9	0.67	3.6	3.1	0.71	3.8	3.0	0.69	4.0	3.1	0.70	4.3	3.1	0.70			
10.0	2.8	2.7	0.58	3.1	2.7	0.59	3.3	2.8	0.61	3.6	2.9	0.63	3.7	3.1	0.67	3.9	3.0	0.65	4.1	3.1	0.67	4.3	3.1	0.67			
20.0	2.9	2.7	0.54	3.1	2.7	0.55	3.3	2.8	0.57	3.6	2.9	0.59	3.8	3.1	0.62	3.9	3.0	0.61	4.1	3.0	0.63	4.3	3.0	0.63			
25.0	2.8	2.6	0.64	3.1	2.6	0.65	3.3	2.7	0.67	3.6	2.8	0.69	3.7	3.0	0.72	3.9	2.9	0.71	4.1	3.0	0.72	4.3	3.0	0.73			
30.0	2.8	2.5	0.77	3.0	2.6	0.78	3.2	2.7	0.80	3.5	2.8	0.82	3.7	3.0	0.84	3.8	2.9	0.84	4.0	3.0	0.85	4.3	3.0	0.86			
35.0	2.8	2.5	0.90	3.0	2.5	0.91	3.2	2.6	0.93	3.5	2.7	0.94	2.5	2.0	0.57	3.8	2.8	0.96	4.0	2.9	0.97	4.3	2.9	0.98			
40.0	2.6	2.3	1.00	2.8	2.4	1.01	3.0	2.5	1.02	3.3	2.6	1.04	3.4	2.7	1.06	3.6	2.7	1.06	3.8	2.7	1.08	4.0	2.7	1.09			
43.0	2.5	2.2	1.05	2.7	2.3	1.07	2.8	2.4	1.08	3.1	2.5	1.10	3.3	2.6	1.12	3.4	2.5	1.12	3.6	2.6	1.14	3.8	2.6	1.15			
46.0	2.4	2.1	1.11	2.6	2.2	1.12	2.7	2.3	1.14	3.0	2.3	1.16	3.1	2.5	1.18	3.3	2.4	1.18	3.4	2.5	1.20	3.7	2.5	1.21			

Heating

TC : Total Capacity, PI : Power Input

Outdoor Temperature	Indoor Temperature (°C, DB)											
	16.0		18.0		20.0		21.0		22.0		24.0	
DB	TC	PI	TC	PI	TC	PI	TC	PI	TC	PI	TC	PI
°C	kW	kW	kW	kW	kW	kW	kW	kW	kW	kW	kW	kW
-15.0	3.6	1.59	3.6	1.62	3.5	1.65	3.5	1.66	3.5	1.66	3.4	1.70
-10.0	4.2	1.80	4.1	1.84	4.1	1.88	4.0	1.88	4.0	1.89	3.9	1.93
-5.0	4.8	1.96	4.7	2.00	4.6	2.04	4.6	2.06	4.6	2.07	4.5	2.11
0	5.4	2.12	5.3	2.17	5.2	2.21	5.2	2.23	5.1	2.24	5.0	2.29
2.0	5.2	1.91	5.1	1.95	5.0	1.99	4.9	2.00	4.9	2.02	4.8	2.06
5.0	4.8	1.59	4.7	1.62	4.6	1.66	4.6	1.67	4.6	1.68	4.5	1.71
7.0	4.6	1.38	4.5	1.41	4.4	1.44	4.4	1.44	4.3	1.46	4.3	1.48
10.0	4.7	1.35	4.6	1.38	4.5	1.41	4.4	1.42	4.4	1.43	4.3	1.45
15.0	4.8	1.30	4.7	1.33	4.6	1.36	4.6	1.37	4.6	1.38	4.5	1.40
20.0	4.9	1.26	4.8	1.28	4.7	1.31	4.7	1.32	4.7	1.33	4.6	1.35
24.0	5.1	1.22	5.0	1.25	4.8	1.27	4.8	1.28	4.8	1.29	4.7	1.31

NOTE

- The performance table shows the average value of each conditions.

4. Capacity Table

Première

AR70H12C1AWNEU + AR70H12C1AWXEU

Cooling

TC : Total Capacity, SHC : Sensible Heat Capacity, PI : Power Input

Outdoor Temperature	Indoor Temperature (°C, DB / WB)																										
	18.0/12.0			20.0/14.0			22.0/16.0			25.0/18.0			27.0/19.0			28.0/20.0			30.0/22.0			32.0/24.0					
DB	TC	SHC	PI	TC	SHC	PI	TC	SHC	PI	TC	SHC	PI	TC	SHC	PI	TC	SHC	PI	TC	SHC	PI	TC	SHC	PI	TC	SHC	PI
°C	kW	kW	kW	kW	kW	kW	kW	kW	kW	kW	kW	kW	kW	kW	kW	kW	kW	kW	kW	kW	kW	kW	kW	kW	kW	kW	kW
-10.0	2.8	2.5	0.80	3.0	2.5	0.81	3.2	2.6	0.84	3.5	2.7	0.87	3.6	2.9	0.93	3.8	2.8	0.90	4.0	2.9	0.92	4.3	2.9	0.92			
0	3.0	2.7	0.73	3.3	2.7	0.73	3.5	2.8	0.76	3.8	2.9	0.79	4.0	3.1	0.84	4.2	3.0	0.82	4.4	3.1	0.83	4.7	3.1	0.83			
10.0	3.1	2.7	0.67	3.3	2.7	0.68	3.5	2.8	0.71	3.9	2.9	0.73	4.0	3.1	0.77	4.2	3.0	0.76	4.4	3.1	0.77	4.7	3.1	0.78			
20.0	3.2	2.7	0.64	3.4	2.7	0.64	3.6	2.8	0.67	3.9	2.9	0.69	4.1	3.1	0.73	4.3	3.0	0.72	4.5	3.1	0.73	4.7	3.1	0.74			
25.0	3.2	2.7	0.83	3.5	2.8	0.84	3.7	2.9	0.86	4.0	3.0	0.89	4.2	3.2	0.92	4.4	3.1	0.91	4.6	3.1	0.93	4.9	3.1	0.94			
30.0	3.3	2.8	1.07	3.6	2.8	1.08	3.8	2.9	1.10	4.2	3.0	1.13	4.3	3.2	1.15	4.5	3.1	1.15	4.8	3.2	1.17	5.0	3.2	1.18			
35.0	3.4	2.8	1.31	3.7	2.8	1.33	3.9	3.0	1.35	4.3	3.1	1.37	3.5	2.8	0.90	4.7	3.2	1.40	4.9	3.3	1.41	5.2	3.3	1.43			
40.0	3.2	2.6	1.42	3.4	2.7	1.44	3.6	2.8	1.46	4.0	2.9	1.49	4.2	3.1	1.51	4.3	3.0	1.52	4.6	3.1	1.53	4.9	3.1	1.55			
43.0	3.0	2.5	1.49	3.3	2.6	1.51	3.5	2.7	1.53	3.8	2.8	1.56	4.0	3.0	1.58	4.2	2.9	1.59	4.4	3.0	1.61	4.7	3.0	1.62			
46.0	2.9	2.4	1.55	3.1	2.5	1.57	3.3	2.6	1.60	3.7	2.7	1.63	3.8	2.8	1.65	4.0	2.8	1.66	4.2	2.8	1.68	4.5	2.8	1.70			

Heating

TC : Total Capacity, PI : Power Input

Outdoor Temperature	Indoor Temperature (°C, DB)											
	16.0		18.0		20.0		21.0		22.0		24.0	
DB	TC	PI	TC	PI	TC	PI	TC	PI	TC	PI	TC	PI
°C	kW	kW	kW	kW	kW	kW	kW	kW	kW	kW	kW	kW
-15.0	4.2	2.02	4.1	2.06	4.0	2.10	4.0	2.11	4.0	2.12	3.9	2.16
-10.0	4.7	2.24	4.6	2.28	4.5	2.33	4.5	2.34	4.5	2.35	4.4	2.39
-5.0	5.0	2.21	4.9	2.25	4.8	2.30	4.8	2.32	4.8	2.33	4.7	2.38
0	5.3	2.18	5.2	2.22	5.1	2.27	5.1	2.29	5.0	2.30	4.9	2.35
2.0	5.2	1.94	5.1	1.98	5.0	2.02	4.9	2.03	4.9	2.05	4.8	2.09
5.0	5.0	1.57	4.9	1.60	4.8	1.64	4.8	1.65	4.7	1.66	4.6	1.69
7.0	4.8	1.33	4.8	1.36	4.0	1.07	4.7	1.39	4.6	1.40	4.5	1.43
10.0	4.8	1.26	4.8	1.28	4.7	1.31	4.6	1.32	4.6	1.33	4.5	1.35
15.0	4.9	1.17	4.8	1.19	4.7	1.22	4.7	1.23	4.7	1.24	4.6	1.26
20.0	5.1	1.21	5.0	1.23	4.9	1.26	4.9	1.27	4.9	1.28	4.8	1.30
24.0	5.3	1.24	5.2	1.27	5.1	1.29	5.1	1.30	5.1	1.31	5.0	1.34

NOTE

- The performance table shows the average value of each conditions.

4. Capacity Table

Première

AR70H15C1AWNEU + AR70H15C1AWXEU

Cooling

TC : Total Capacity, SHC : Sensible Heat Capacity, PI : Power Input

Outdoor Temperature	Indoor Temperature (°C, DB / WB)																										
	18.0/12.0			20.0/14.0			22.0/16.0			25.0/18.0			27.0/19.0			28.0/20.0			30.0/22.0			32.0/24.0					
DB	TC	SHC	PI	TC	SHC	PI	TC	SHC	PI	TC	SHC	PI	TC	SHC	PI	TC	SHC	PI	TC	SHC	PI	TC	SHC	PI	TC	SHC	PI
°C	kW	kW	kW	kW	kW	kW	kW	kW	kW	kW	kW	kW	kW	kW	kW	kW	kW	kW	kW	kW	kW	kW	kW	kW	kW	kW	kW
-10.0	3.2	2.8	0.98	3.5	2.8	0.98	3.7	2.9	1.03	4.1	3.0	1.06	4.2	3.2	1.13	4.4	3.2	1.10	4.7	3.2	1.12	4.9	3.2	1.12			
0	3.4	2.9	0.91	3.7	2.9	0.91	3.9	3.1	0.95	4.3	3.2	0.98	4.4	3.4	1.05	4.7	3.3	1.02	4.9	3.4	1.04	5.2	3.4	1.04			
10.0	3.5	3.0	0.82	3.8	3.0	0.83	4.1	3.1	0.86	4.4	3.2	0.90	4.6	3.4	0.95	4.8	3.3	0.93	5.1	3.4	0.95	5.4	3.4	0.95			
20.0	3.6	3.0	0.79	3.9	3.0	0.80	4.1	3.1	0.83	4.5	3.2	0.86	4.7	3.5	0.91	4.9	3.3	0.89	5.1	3.4	0.91	5.4	3.4	0.92			
25.0	3.6	3.0	0.98	3.9	3.0	1.00	4.2	3.2	1.02	4.6	3.3	1.05	4.7	3.5	1.09	4.9	3.4	1.08	5.2	3.5	1.10	5.5	3.5	1.11			
30.0	3.7	3.0	1.22	4.0	3.0	1.24	4.2	3.2	1.26	4.6	3.3	1.29	4.8	3.5	1.32	5.0	3.4	1.32	5.3	3.5	1.34	5.6	3.5	1.35			
35.0	3.7	3.0	1.46	4.0	3.1	1.48	4.3	3.2	1.50	4.7	3.3	1.52	4.3	3.4	1.18	5.1	3.5	1.55	5.4	3.5	1.57	5.8	3.5	1.59			
40.0	3.5	2.8	1.58	3.8	2.9	1.60	4.0	3.0	1.62	4.4	3.1	1.65	4.6	3.3	1.67	4.8	3.2	1.68	5.1	3.3	1.70	5.4	3.3	1.72			
43.0	3.3	2.7	1.65	3.6	2.7	1.67	3.8	2.9	1.69	4.2	3.0	1.72	4.4	3.2	1.75	4.6	3.1	1.76	4.8	3.2	1.78	5.2	3.2	1.80			
46.0	3.2	2.6	1.72	3.5	2.6	1.74	3.7	2.7	1.76	4.0	2.8	1.80	4.2	3.0	1.82	4.4	3.0	1.83	4.6	3.0	1.85	4.9	3.0	1.88			

Heating

TC : Total Capacity, PI : Power Input

Outdoor Temperature	Indoor Temperature (°C, DB)											
	16.0		18.0		20.0		21.0		22.0		24.0	
DB	TC	PI	TC	PI	TC	PI	TC	PI	TC	PI	TC	PI
°C	kW	kW	kW	kW	kW	kW	kW	kW	kW	kW	kW	kW
-15.0	4.3	1.92	4.3	1.96	4.2	2.00	4.2	2.01	4.1	2.02	4.1	2.06
-10.0	4.9	2.11	4.8	2.14	4.7	2.19	4.7	2.20	4.7	2.21	4.6	2.25
-5.0	5.3	2.03	5.2	2.07	5.1	2.11	5.1	2.12	5.1	2.14	4.9	2.18
0	5.7	1.95	5.6	1.99	5.5	2.03	5.5	2.05	5.4	2.06	5.3	2.10
2.0	5.7	1.81	5.6	1.84	5.4	1.88	5.4	1.89	5.4	1.91	5.3	1.94
5.0	5.6	1.59	5.5	1.62	5.4	1.65	5.3	1.66	5.3	1.68	5.2	1.71
7.0	5.5	1.44	5.4	1.47	4.7	1.26	5.3	1.51	5.3	1.52	5.2	1.55
10.0	5.6	1.36	5.5	1.39	5.4	1.42	5.4	1.43	5.3	1.44	5.2	1.47
15.0	5.7	1.27	5.6	1.29	5.5	1.32	5.5	1.33	5.4	1.34	5.3	1.36
20.0	5.9	1.31	5.8	1.33	5.7	1.36	5.7	1.37	5.6	1.38	5.5	1.41
24.0	6.0	1.34	5.9	1.37	5.8	1.40	5.8	1.41	5.8	1.42	5.6	1.44

NOTE

- The performance table shows the average value of each conditions.

4. Capacity Table

Première

AR70H18C1AWNEU + AR70H18C1AWXEU

Cooling

TC : Total Capacity, SHC : Sensible Heat Capacity, PI : Power Input

Outdoor Temperature	Indoor Temperature (°C, DB / WB)																										
	18.0/12.0			20.0/14.0			22.0/16.0			25.0/18.0			27.0/19.0			28.0/20.0			30.0/22.0			32.0/24.0					
DB	TC	SHC	PI	TC	SHC	PI	TC	SHC	PI	TC	SHC	PI	TC	SHC	PI	TC	SHC	PI	TC	SHC	PI	TC	SHC	PI	TC	SHC	PI
°C	kW	kW	kW	kW	kW	kW	kW	kW	kW	kW	kW	kW	kW	kW	kW	kW	kW	kW	kW	kW	kW	kW	kW	kW	kW	kW	kW
-10.0	4.7	4.0	0.79	5.1	4.0	0.79	5.4	4.2	0.83	5.9	4.3	0.86	6.1	4.6	0.91	6.4	4.5	0.88	6.8	4.6	0.90	7.2	4.7	0.90			
0	4.5	3.8	0.91	4.9	3.8	0.92	5.2	4.0	0.96	5.7	4.2	0.99	5.8	4.4	1.05	6.2	4.3	1.02	6.5	4.4	1.04	6.9	4.5	1.04			
10.0	4.5	3.7	0.87	4.9	3.8	0.88	5.2	3.9	0.92	5.6	4.1	0.95	5.9	4.3	1.00	6.1	4.2	0.98	6.4	4.3	1.01	6.8	4.3	1.01			
20.0	4.5	3.7	0.88	4.8	3.7	0.89	5.1	3.8	0.92	5.6	4.0	0.96	5.8	4.2	1.01	6.1	4.1	0.99	6.4	4.2	1.02	6.7	4.2	1.02			
25.0	4.6	3.7	1.19	4.9	3.8	1.20	5.2	3.9	1.24	5.7	4.1	1.27	6.0	4.3	1.32	6.2	4.2	1.31	6.6	4.3	1.33	6.9	4.3	1.34			
30.0	4.7	3.8	1.57	5.1	3.8	1.59	5.4	4.0	1.62	5.9	4.2	1.65	6.2	4.4	1.69	6.5	4.3	1.69	6.8	4.4	1.72	7.2	4.4	1.73			
35.0	4.8	3.9	1.95	5.3	3.9	1.97	5.6	4.1	2.00	6.1	4.3	2.04	5.0	4.0	1.39	6.7	4.4	2.08	7.1	4.5	2.10	7.5	4.6	2.12			
40.0	4.3	3.5	1.91	4.7	3.5	1.93	5.0	3.7	1.96	5.5	3.8	2.00	5.7	4.1	2.02	6.0	4.0	2.03	6.3	4.1	2.06	6.7	4.1	2.08			
43.0	4.0	3.3	1.88	4.4	3.3	1.91	4.7	3.4	1.93	5.1	3.6	1.97	5.3	3.8	2.00	5.6	3.7	2.01	5.9	3.8	2.03	6.3	3.8	2.06			
46.0	3.7	3.0	1.86	4.1	3.0	1.88	4.3	3.2	1.91	4.7	3.3	1.95	4.9	3.5	1.97	5.2	3.4	1.98	5.4	3.5	2.01	5.8	3.5	2.03			

Heating

TC : Total Capacity, PI : Power Input

Outdoor Temperature	Indoor Temperature (°C, DB)											
	16.0		18.0		20.0		21.0		22.0		24.0	
DB	TC	PI	TC	PI	TC	PI	TC	PI	TC	PI	TC	PI
°C	kW	kW	kW	kW	kW	kW	kW	kW	kW	kW	kW	kW
-15.0	4.5	1.71	4.4	1.74	4.3	1.77	4.3	1.78	4.3	1.79	4.2	1.82
-10.0	5.2	1.87	5.1	1.90	5.0	1.94	5.0	1.95	4.9	1.96	4.8	2.00
-5.0	6.0	2.04	5.9	2.08	5.7	2.13	5.7	2.14	5.7	2.16	5.6	2.20
0	6.1	1.87	6.0	1.91	5.9	1.95	5.8	1.96	5.8	1.97	5.7	2.01
2.0	6.2	1.84	6.1	1.88	6.0	1.92	6.0	1.93	5.9	1.94	5.8	1.98
5.0	6.4	1.79	6.3	1.83	6.2	1.87	6.2	1.88	6.1	1.89	6.0	1.93
7.0	6.6	1.76	6.4	1.79	6.0	1.61	6.3	1.84	6.3	1.86	6.1	1.89
10.0	7.0	1.84	6.8	1.88	6.7	1.92	6.7	1.93	6.7	1.95	6.5	1.98
15.0	7.6	1.95	7.4	1.99	7.3	2.04	7.3	2.05	7.2	2.06	7.1	2.10
20.0	7.8	1.96	7.7	2.00	7.5	2.04	7.5	2.05	7.4	2.07	7.3	2.11
24.0	8.0	1.96	7.8	2.00	7.7	2.04	7.6	2.05	7.6	2.07	7.4	2.11

NOTE

- The performance table shows the average value of each conditions.

4. Capacity Table

Première

AR70H24C1AWNEU + AR70H24C1AWXEU

Cooling

TC : Total Capacity, SHC : Sensible Heat Capacity, PI : Power Input

Outdoor Temperature	Indoor Temperature (°C, DB / WB)																										
	18.0/12.0			20.0/14.0			22.0/16.0			25.0/18.0			27.0/19.0			28.0/20.0			30.0/22.0			32.0/24.0					
DB	TC	SHC	PI	TC	SHC	PI	TC	SHC	PI	TC	SHC	PI	TC	SHC	PI	TC	SHC	PI	TC	SHC	PI	TC	SHC	PI	TC	SHC	PI
°C	kW	kW	kW	kW	kW	kW	kW	kW	kW	kW	kW	kW	kW	kW	kW	kW	kW	kW	kW	kW	kW	kW	kW	kW	kW	kW	kW
-10.0	3.2	2.5	0.98	3.5	2.6	0.98	3.7	2.7	1.03	4.1	2.8	1.06	4.2	3.0	1.13	4.4	2.9	1.10	4.7	3.0	1.12	4.9	3.0	1.12			
0	3.4	2.7	0.91	3.7	2.7	0.91	3.9	2.8	0.95	4.3	3.0	0.98	4.4	3.2	1.05	4.7	3.1	1.02	4.9	3.2	1.04	5.2	3.2	1.04			
10.0	3.5	2.8	0.82	3.8	2.8	0.83	4.1	2.9	0.86	4.4	3.0	0.90	4.6	3.2	0.95	4.8	3.1	0.93	5.1	3.2	0.95	5.4	3.2	0.95			
20.0	3.6	2.8	0.79	3.9	2.8	0.80	4.1	2.9	0.83	4.5	3.0	0.86	4.7	3.2	0.91	4.9	3.1	0.89	5.1	3.2	0.91	5.4	3.2	0.92			
25.0	3.6	2.8	0.98	3.9	2.8	1.00	4.2	2.9	1.02	4.6	3.0	1.05	4.7	3.2	1.09	4.9	3.1	1.08	5.2	3.2	1.10	5.5	3.2	1.11			
30.0	3.7	2.8	1.22	4.0	2.8	1.24	4.2	3.0	1.26	4.6	3.1	1.29	4.8	3.3	1.32	5.0	3.2	1.32	5.3	3.3	1.34	5.6	3.3	1.35			
35.0	3.7	2.8	1.46	4.0	2.8	1.48	4.3	3.0	1.50	4.7	3.1	1.52	6.5	5.2	1.95	5.1	3.2	1.55	5.4	3.3	1.57	5.8	3.3	1.59			
40.0	3.5	2.6	1.58	3.8	2.7	1.60	4.0	2.8	1.62	4.4	2.9	1.65	4.6	3.1	1.67	4.8	3.0	1.68	5.1	3.1	1.70	5.4	3.1	1.72			
43.0	3.3	2.5	1.65	3.6	2.5	1.67	3.8	2.7	1.69	4.2	2.8	1.72	4.4	2.9	1.75	4.6	2.9	1.76	4.8	2.9	1.78	5.2	3.0	1.80			
46.0	3.2	2.4	1.72	3.5	2.4	1.74	3.7	2.5	1.76	4.0	2.7	1.80	4.2	2.8	1.82	4.4	2.8	1.83	4.6	2.8	1.85	4.9	2.8	1.88			

Heating

TC : Total Capacity, PI : Power Input

Outdoor Temperature	Indoor Temperature (°C, DB)											
	16.0		18.0		20.0		21.0		22.0		24.0	
DB	TC	PI	TC	PI	TC	PI	TC	PI	TC	PI	TC	PI
°C	kW	kW	kW	kW	kW	kW	kW	kW	kW	kW	kW	kW
-15.0	5.4	2.15	5.3	2.18	5.2	2.23	5.2	2.24	5.2	2.25	5.1	2.29
-10.0	6.3	2.34	6.2	2.38	6.1	2.44	6.1	2.44	6.0	2.46	5.9	2.50
-5.0	6.9	2.36	6.8	2.41	6.6	2.46	6.6	2.48	6.6	2.50	6.4	2.55
0	7.5	2.39	7.3	2.44	7.2	2.49	7.2	2.51	7.1	2.52	7.0	2.57
2.0	7.7	2.35	7.6	2.39	7.4	2.44	7.4	2.46	7.3	2.48	7.2	2.53
5.0	8.0	2.28	7.9	2.32	7.7	2.37	7.7	2.39	7.6	2.40	7.5	2.45
7.0	8.2	2.23	8.1	2.28	7.4	2.20	7.9	2.34	7.8	2.36	7.7	2.40
10.0	8.7	2.35	8.6	2.40	8.4	2.45	8.4	2.46	8.3	2.48	8.1	2.53
15.0	9.5	2.50	9.3	2.55	9.1	2.60	9.1	2.62	9.0	2.64	8.8	2.69
20.0	9.6	2.45	9.4	2.49	9.2	2.55	9.2	2.56	9.2	2.58	9.0	2.63
24.0	9.8	2.40	9.6	2.45	9.4	2.51	9.3	2.52	9.3	2.54	9.1	2.59

NOTE

- The performance table shows the average value of each conditions.

4. Capacity Table

Première Black

AR70H07C1ABNEU + AR70H07C1AWXEU

Cooling

TC : Total Capacity, SHC : Sensible Heat Capacity, PI : Power Input

Outdoor Temperature	Indoor Temperature (°C, DB / WB)																										
	18.0/12.0			20.0/14.0			22.0/16.0			25.0/18.0			27.0/19.0			28.0/20.0			30.0/22.0			32.0/24.0					
DB	TC	SHC	PI	TC	SHC	PI	TC	SHC	PI	TC	SHC	PI	TC	SHC	PI	TC	SHC	PI	TC	SHC	PI	TC	SHC	PI	TC	SHC	PI
°C	kW	kW	kW	kW	kW	kW	kW	kW	kW	kW	kW	kW	kW	kW	kW	kW	kW	kW	kW	kW	kW	kW	kW	kW	kW	kW	kW
-10.0	2.1	2.0	0.48	2.3	2.0	0.48	2.4	2.1	0.50	2.7	2.2	0.52	2.8	2.4	0.55	2.9	2.3	0.54	3.1	2.4	0.55	3.3	2.4	0.55			
0	2.4	2.3	0.41	2.6	2.3	0.41	2.7	2.4	0.43	3.0	2.5	0.44	3.1	2.6	0.47	3.3	2.6	0.46	3.4	2.7	0.47	3.7	2.7	0.46			
10.0	2.3	2.2	0.42	2.5	2.2	0.43	2.7	2.3	0.45	2.9	2.4	0.46	3.0	2.5	0.49	3.2	2.4	0.48	3.3	2.5	0.49	3.5	2.5	0.49			
20.0	2.4	2.2	0.39	2.6	2.3	0.40	2.8	2.3	0.41	3.0	2.4	0.43	3.2	2.6	0.45	3.3	2.5	0.44	3.5	2.6	0.46	3.7	2.6	0.46			
25.0	2.5	2.3	0.50	2.7	2.3	0.51	2.8	2.4	0.52	3.1	2.5	0.54	3.2	2.6	0.56	3.4	2.6	0.55	3.5	2.6	0.56	3.8	2.6	0.57			
30.0	2.5	2.3	0.65	2.7	2.3	0.66	2.9	2.4	0.67	3.2	2.5	0.69	3.3	2.6	0.70	3.4	2.6	0.70	3.6	2.6	0.71	3.8	2.6	0.72			
35.0	2.5	2.3	0.80	2.7	2.3	0.81	2.9	2.4	0.82	3.2	2.5	0.84	2.0	1.6	0.43	3.5	2.6	0.85	3.7	2.7	0.86	3.9	2.7	0.87			
40.0	2.3	2.1	0.89	2.5	2.1	0.90	2.7	2.2	0.91	3.0	2.3	0.93	3.1	2.5	0.94	3.2	2.4	0.94	3.4	2.5	0.96	3.6	2.5	0.97			
43.0	2.2	2.0	0.94	2.4	2.0	0.95	2.5	2.1	0.96	2.8	2.2	0.98	2.9	2.3	0.99	3.1	2.3	1.00	3.2	2.3	1.01	3.4	2.3	1.02			
46.0	2.1	1.9	0.99	2.3	1.9	1.00	2.4	2.0	1.01	2.7	2.1	1.03	2.8	2.2	1.05	2.9	2.2	1.05	3.1	2.2	1.07	3.3	2.2	1.08			

Heating

TC : Total Capacity, PI : Power Input

Outdoor Temperature	Indoor Temperature (°C, DB)											
	16.0		18.0		20.0		21.0		22.0		24.0	
DB	TC	PI	TC	PI	TC	PI	TC	PI	TC	PI	TC	PI
°C	kW	kW	kW	kW	kW	kW	kW	kW	kW	kW	kW	kW
-15.0	3.6	1.67	3.5	1.70	3.5	1.73	3.5	1.74	3.4	1.75	3.4	1.78
-10.0	4.2	1.86	4.1	1.90	4.0	1.94	4.0	1.95	4.0	1.95	3.9	1.99
-5.0	4.3	1.72	4.2	1.75	4.1	1.79	4.1	1.80	4.1	1.81	4.0	1.85
0	4.4	1.58	4.4	1.61	4.3	1.64	4.3	1.65	4.2	1.67	4.1	1.70
2.0	4.4	1.50	4.3	1.53	4.2	1.56	4.2	1.57	4.2	1.58	4.1	1.61
5.0	4.3	1.38	4.3	1.41	4.2	1.44	4.2	1.45	4.1	1.46	4.1	1.49
7.0	4.3	1.30	4.2	1.33	2.2	0.46	4.1	1.36	4.1	1.37	4.0	1.40
10.0	4.4	1.28	4.3	1.30	4.2	1.33	4.2	1.34	4.2	1.35	4.1	1.38
15.0	4.6	1.24	4.5	1.26	4.4	1.29	4.4	1.30	4.3	1.31	4.3	1.33
20.0	4.7	1.20	4.6	1.22	4.5	1.25	4.5	1.26	4.5	1.26	4.4	1.29
24.0	4.8	1.17	4.7	1.19	4.6	1.21	4.6	1.22	4.6	1.23	4.5	1.26

NOTE

- The performance table shows the average value of each conditions.

4. Capacity Table

Première Black

AR70H09C1ABNEU + AR70H09C1AWXEU

Cooling

TC : Total Capacity, SHC : Sensible Heat Capacity, PI : Power Input

Outdoor Temperature	Indoor Temperature (°C, DB / WB)																										
	18.0/12.0			20.0/14.0			22.0/16.0			25.0/18.0			27.0/19.0			28.0/20.0			30.0/22.0			32.0/24.0					
	DB	TC	SHC	PI	TC	SHC	PI	TC	SHC	PI	TC	SHC	PI	TC	SHC	PI	TC	SHC	PI	TC	SHC	PI	TC	SHC	PI		
°C	kW	kW	kW	kW	kW	kW	kW	kW	kW	kW	kW	kW	kW	kW	kW	kW	kW	kW	kW	kW	kW	kW	kW	kW	kW	kW	kW
-10.0	2.6	2.5	0.68	2.9	2.5	0.68	3.0	2.7	0.71	3.3	2.8	0.73	3.4	2.9	0.78	3.6	2.9	0.76	3.8	2.9	0.78	4.1	3.0	0.77			
0	2.8	2.6	0.62	3.0	2.7	0.62	3.2	2.8	0.65	3.5	2.9	0.67	3.6	3.1	0.71	3.8	3.0	0.69	4.0	3.1	0.70	4.3	3.1	0.70			
10.0	2.8	2.7	0.58	3.1	2.7	0.59	3.3	2.8	0.61	3.6	2.9	0.63	3.7	3.1	0.67	3.9	3.0	0.65	4.1	3.1	0.67	4.3	3.1	0.67			
20.0	2.9	2.7	0.54	3.1	2.7	0.55	3.3	2.8	0.57	3.6	2.9	0.59	3.8	3.1	0.62	3.9	3.0	0.61	4.1	3.0	0.63	4.3	3.0	0.63			
25.0	2.8	2.6	0.64	3.1	2.6	0.65	3.3	2.7	0.67	3.6	2.8	0.69	3.7	3.0	0.72	3.9	2.9	0.71	4.1	3.0	0.72	4.3	3.0	0.73			
30.0	2.8	2.5	0.77	3.0	2.6	0.78	3.2	2.7	0.80	3.5	2.8	0.82	3.7	3.0	0.84	3.8	2.9	0.84	4.0	3.0	0.85	4.3	3.0	0.86			
35.0	2.8	2.5	0.90	3.0	2.5	0.91	3.2	2.6	0.93	3.5	2.7	0.94	2.5	2.0	0.57	3.8	2.8	0.96	4.0	2.9	0.97	4.3	2.9	0.98			
40.0	2.6	2.3	1.00	2.8	2.4	1.01	3.0	2.5	1.02	3.3	2.6	1.04	3.4	2.7	1.06	3.6	2.7	1.06	3.8	2.7	1.08	4.0	2.7	1.09			
43.0	2.5	2.2	1.05	2.7	2.3	1.07	2.8	2.4	1.08	3.1	2.5	1.10	3.3	2.6	1.12	3.4	2.5	1.12	3.6	2.6	1.14	3.8	2.6	1.15			
46.0	2.4	2.1	1.11	2.6	2.2	1.12	2.7	2.3	1.14	3.0	2.3	1.16	3.1	2.5	1.18	3.3	2.4	1.18	3.4	2.5	1.20	3.7	2.5	1.21			

Heating

TC : Total Capacity, PI : Power Input

Outdoor Temperature	Indoor Temperature (°C, DB)											
	16.0		18.0		20.0		21.0		22.0		24.0	
	DB	TC	PI	TC	PI	TC	PI	TC	PI	TC	PI	TC
°C	kW	kW	kW	kW	kW	kW	kW	kW	kW	kW	kW	kW
-15.0	3.6	1.59	3.6	1.62	3.5	1.65	3.5	1.66	3.5	1.66	3.4	1.70
-10.0	4.2	1.80	4.1	1.84	4.1	1.88	4.0	1.88	4.0	1.89	3.9	1.93
-5.0	4.8	1.96	4.7	2.00	4.6	2.04	4.6	2.06	4.6	2.07	4.5	2.11
0	5.4	2.12	5.3	2.17	5.2	2.21	5.2	2.23	5.1	2.24	5.0	2.29
2.0	5.2	1.91	5.1	1.95	5.0	1.99	4.9	2.00	4.9	2.02	4.8	2.06
5.0	4.8	1.59	4.7	1.62	4.6	1.66	4.6	1.67	4.6	1.68	4.5	1.71
7.0	4.6	1.38	4.5	1.41	4.4	1.44	4.4	1.44	4.3	1.46	4.3	1.48
10.0	4.7	1.35	4.6	1.38	4.5	1.41	4.4	1.42	4.4	1.43	4.3	1.45
15.0	4.8	1.30	4.7	1.33	4.6	1.36	4.6	1.37	4.6	1.38	4.5	1.40
20.0	4.9	1.26	4.8	1.28	4.7	1.31	4.7	1.32	4.7	1.33	4.6	1.35
24.0	5.1	1.22	5.0	1.25	4.8	1.27	4.8	1.28	4.8	1.29	4.7	1.31

NOTE

- The performance table shows the average value of each conditions.

4. Capacity Table

Première Black

AR70H12C1ABNEU + AR70H12C1AWXEU

Cooling

TC : Total Capacity, SHC : Sensible Heat Capacity, PI : Power Input

Outdoor Temperature	Indoor Temperature (°C, DB / WB)																										
	18.0/12.0			20.0/14.0			22.0/16.0			25.0/18.0			27.0/19.0			28.0/20.0			30.0/22.0			32.0/24.0					
DB	TC	SHC	PI	TC	SHC	PI	TC	SHC	PI	TC	SHC	PI	TC	SHC	PI	TC	SHC	PI	TC	SHC	PI	TC	SHC	PI	TC	SHC	PI
°C	kW	kW	kW	kW	kW	kW	kW	kW	kW	kW	kW	kW	kW	kW	kW	kW	kW	kW	kW	kW	kW	kW	kW	kW	kW	kW	kW
-10.0	2.8	2.5	0.80	3.0	2.5	0.81	3.2	2.6	0.84	3.5	2.7	0.87	3.6	2.9	0.93	3.8	2.8	0.90	4.0	2.9	0.92	4.3	2.9	0.92			
0	3.0	2.7	0.73	3.3	2.7	0.73	3.5	2.8	0.76	3.8	2.9	0.79	4.0	3.1	0.84	4.2	3.0	0.82	4.4	3.1	0.83	4.7	3.1	0.83			
10.0	3.1	2.7	0.67	3.3	2.7	0.68	3.5	2.8	0.71	3.9	2.9	0.73	4.0	3.1	0.77	4.2	3.0	0.76	4.4	3.1	0.77	4.7	3.1	0.78			
20.0	3.2	2.7	0.64	3.4	2.7	0.64	3.6	2.8	0.67	3.9	2.9	0.69	4.1	3.1	0.73	4.3	3.0	0.72	4.5	3.1	0.73	4.7	3.1	0.74			
25.0	3.2	2.7	0.83	3.5	2.8	0.84	3.7	2.9	0.86	4.0	3.0	0.89	4.2	3.2	0.92	4.4	3.1	0.91	4.6	3.1	0.93	4.9	3.1	0.94			
30.0	3.3	2.8	1.07	3.6	2.8	1.08	3.8	2.9	1.10	4.2	3.0	1.13	4.3	3.2	1.15	4.5	3.1	1.15	4.8	3.2	1.17	5.0	3.2	1.18			
35.0	3.4	2.8	1.31	3.7	2.8	1.33	3.9	3.0	1.35	4.3	3.1	1.37	3.5	2.8	0.90	4.7	3.2	1.40	4.9	3.3	1.41	5.2	3.3	1.43			
40.0	3.2	2.6	1.42	3.4	2.7	1.44	3.6	2.8	1.46	4.0	2.9	1.49	4.2	3.1	1.51	4.3	3.0	1.52	4.6	3.1	1.53	4.9	3.1	1.55			
43.0	3.0	2.5	1.49	3.3	2.6	1.51	3.5	2.7	1.53	3.8	2.8	1.56	4.0	3.0	1.58	4.2	2.9	1.59	4.4	3.0	1.61	4.7	3.0	1.62			
46.0	2.9	2.4	1.55	3.1	2.5	1.57	3.3	2.6	1.60	3.7	2.7	1.63	3.8	2.8	1.65	4.0	2.8	1.66	4.2	2.8	1.68	4.5	2.8	1.70			

Heating

TC : Total Capacity, PI : Power Input

Outdoor Temperature	Indoor Temperature (°C, DB)											
	16.0		18.0		20.0		21.0		22.0		24.0	
DB	TC	PI	TC	PI	TC	PI	TC	PI	TC	PI	TC	PI
°C	kW	kW	kW	kW	kW	kW	kW	kW	kW	kW	kW	kW
-15.0	4.2	2.02	4.1	2.06	4.0	2.10	4.0	2.11	4.0	2.12	3.9	2.16
-10.0	4.7	2.24	4.6	2.28	4.5	2.33	4.5	2.34	4.5	2.35	4.4	2.39
-5.0	5.0	2.21	4.9	2.25	4.8	2.30	4.8	2.32	4.8	2.33	4.7	2.38
0	5.3	2.18	5.2	2.22	5.1	2.27	5.1	2.29	5.0	2.30	4.9	2.35
2.0	5.2	1.94	5.1	1.98	5.0	2.02	4.9	2.03	4.9	2.05	4.8	2.09
5.0	5.0	1.57	4.9	1.60	4.8	1.64	4.8	1.65	4.7	1.66	4.6	1.69
7.0	4.8	1.33	4.8	1.36	4.0	1.07	4.7	1.39	4.6	1.40	4.5	1.43
10.0	4.8	1.26	4.8	1.28	4.7	1.31	4.6	1.32	4.6	1.33	4.5	1.35
15.0	4.9	1.17	4.8	1.19	4.7	1.22	4.7	1.23	4.7	1.24	4.6	1.26
20.0	5.1	1.21	5.0	1.23	4.9	1.26	4.9	1.27	4.9	1.28	4.8	1.30
24.0	5.3	1.24	5.2	1.27	5.1	1.29	5.1	1.30	5.1	1.31	5.0	1.34

NOTE

- The performance table shows the average value of each conditions.

5. Dimensional Drawing

Indoor units

AR70H09CAAWNEU, AR70H12CAAWNEU, AR70H09CAABNEU, AR70H12CAABNEU, AR70H07C1AWNEU
AR70H09C1AWNEU, AR70H12C1AWNEU, AR70H15C1AWNEU, AR70H07C1ABNEU, AR70H09C1ABNEU
AR70H12C1ABNEU

Unit: mm [inch]

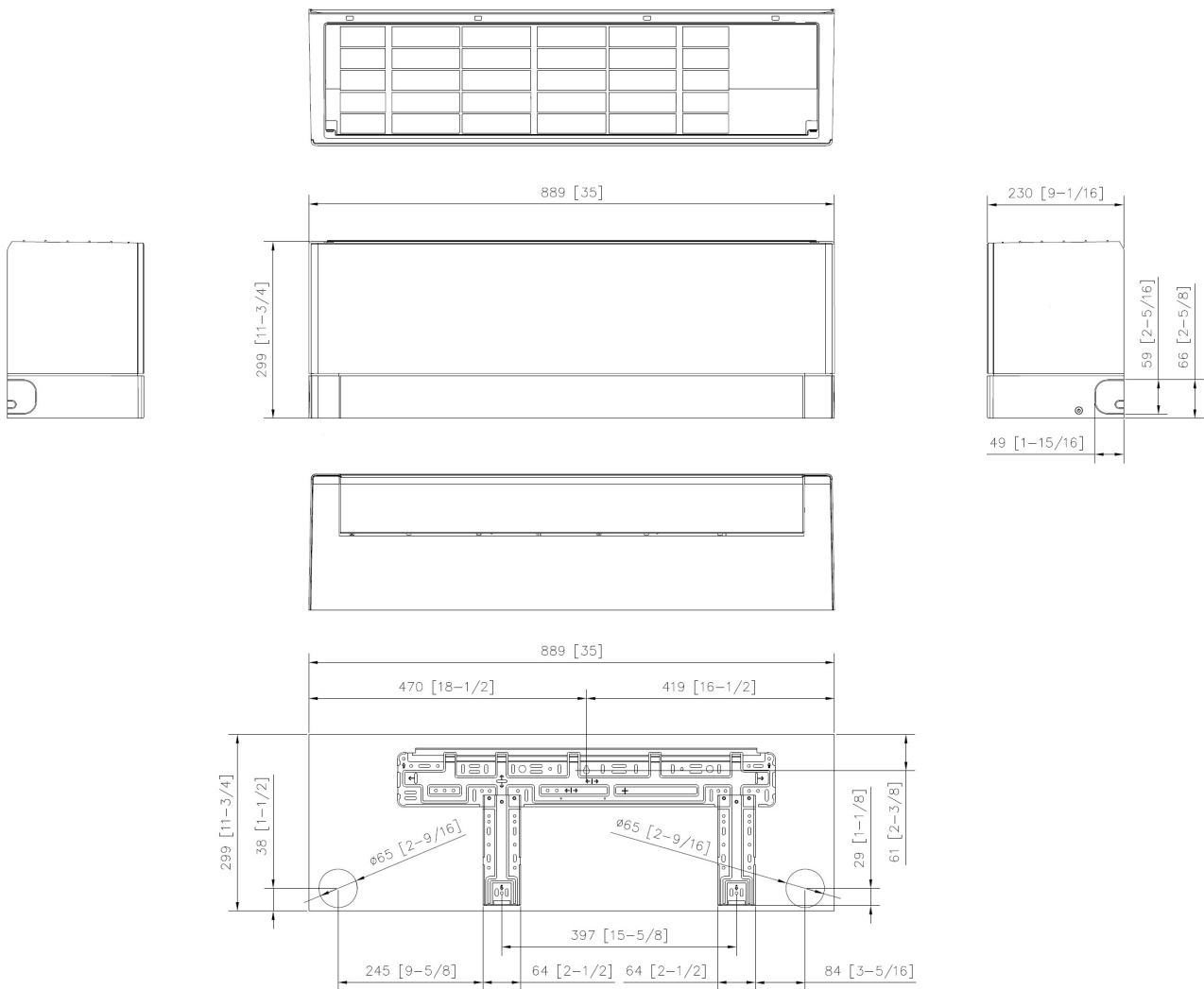

5. Dimensional Drawing

Outdoor Unit

AR70H07C1AWXEU, AR70H09C1AWXEU, AR70H09CAAWXEU, AR70H12C1AWXEU, AR70H12CAAWXEU
AR70H15C1AWXEU

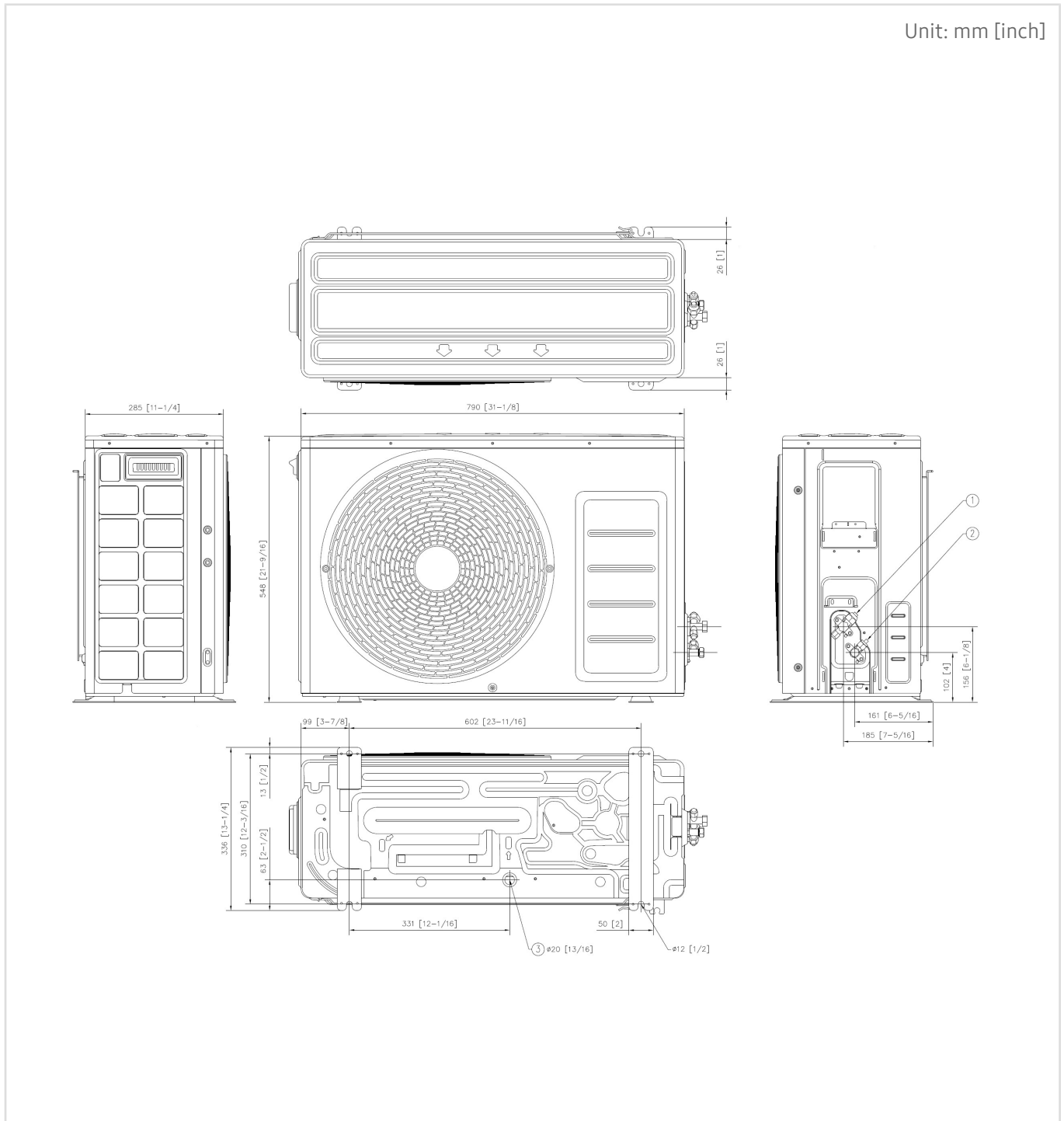

No.	Name	Description
1	Gas pipe connection	9.52
2	Liquid pipe connection	6.35
3	Drain pipe connection	-

5. Dimensional Drawing

Outdoor Unit

AR70H18C1AWXEU, AR70H24C1AWXEU

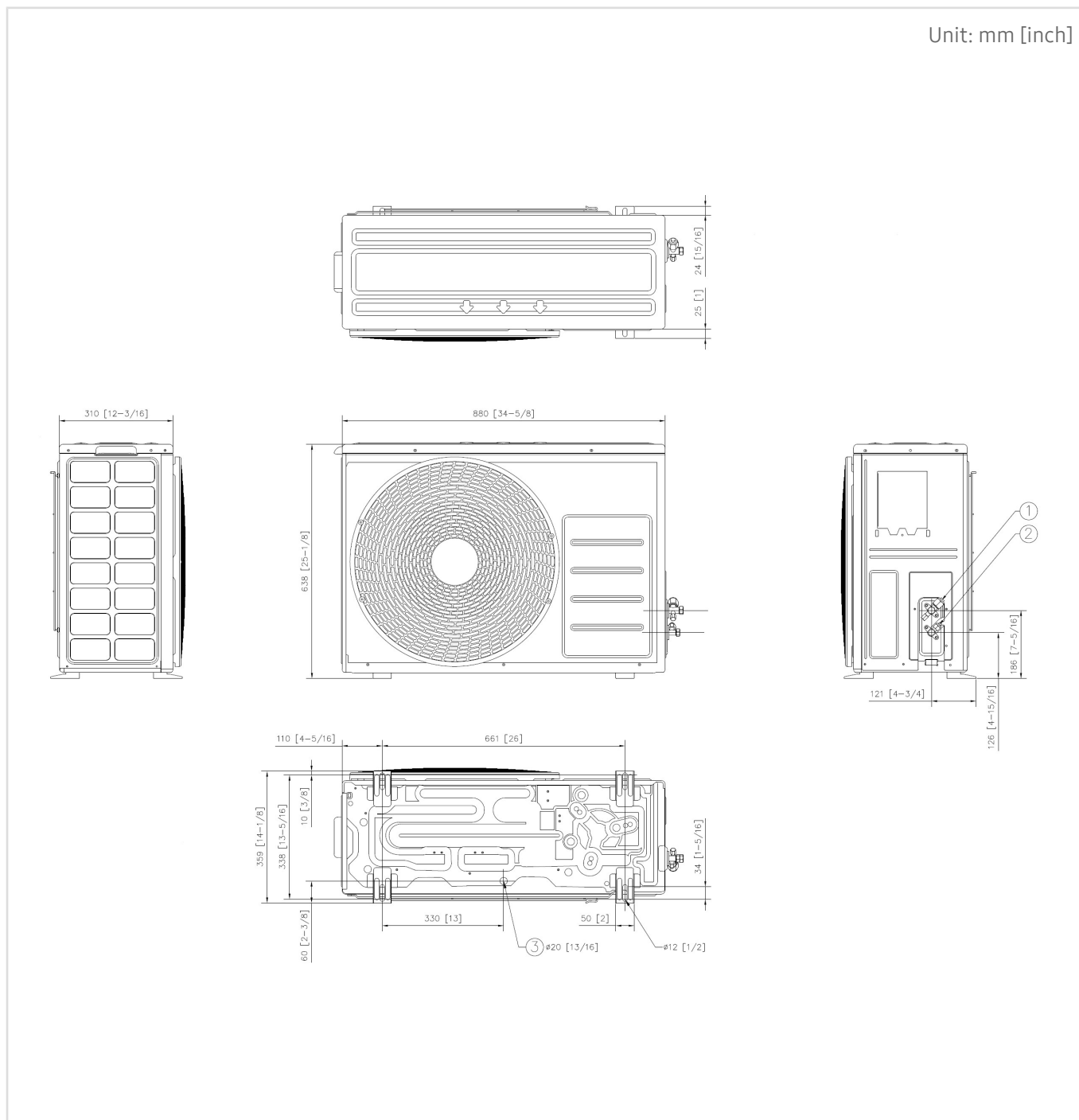

No.	Name	Description	
		AR70H18C1AWX	AR70H24C1AWX
1	Gas pipe connection	12.7	15.88
2	Liquid pipe connection	6.35	
3	Drain pipe connection	-	

6. Center of Gravi

Indoor units

AR70H09CAAWNEU, AR70H12CAAWNEU, AR70H09CAABNEU, AR70H12CAABNEU, AR70H07C1AWNEU
 AR70H09C1AWNEU, AR70H12C1AWNEU, AR70H15C1AWNEU, AR70H07C1ABNEU, AR70H09C1ABNEU
 AR70H12C1ABNEU

Unit: mm [inch]

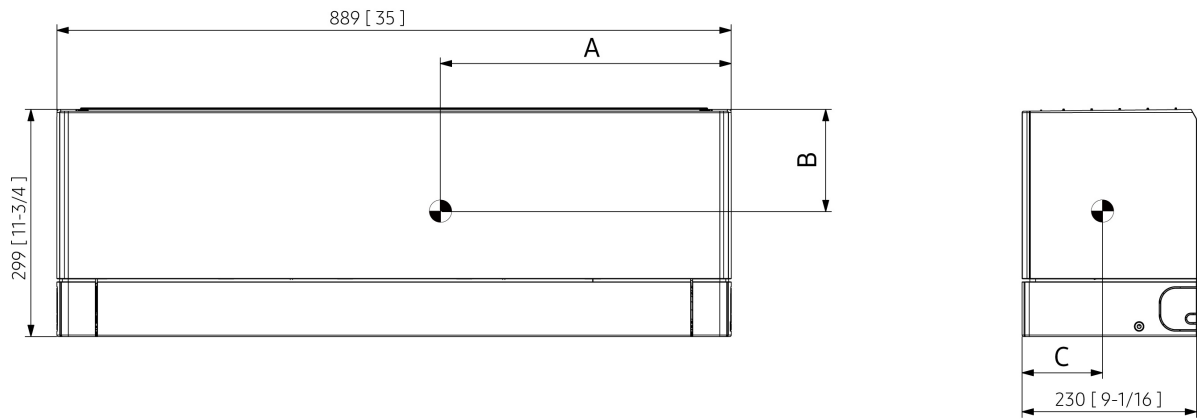

A	B	C
383.5[15-1/8]	157.5[6-3/16]	106[4-3/16]

6. Center of Gravity

Indoor units

AR70H18C1AWNEU, AR70H24C1AWNEU

Unit: mm [inch]

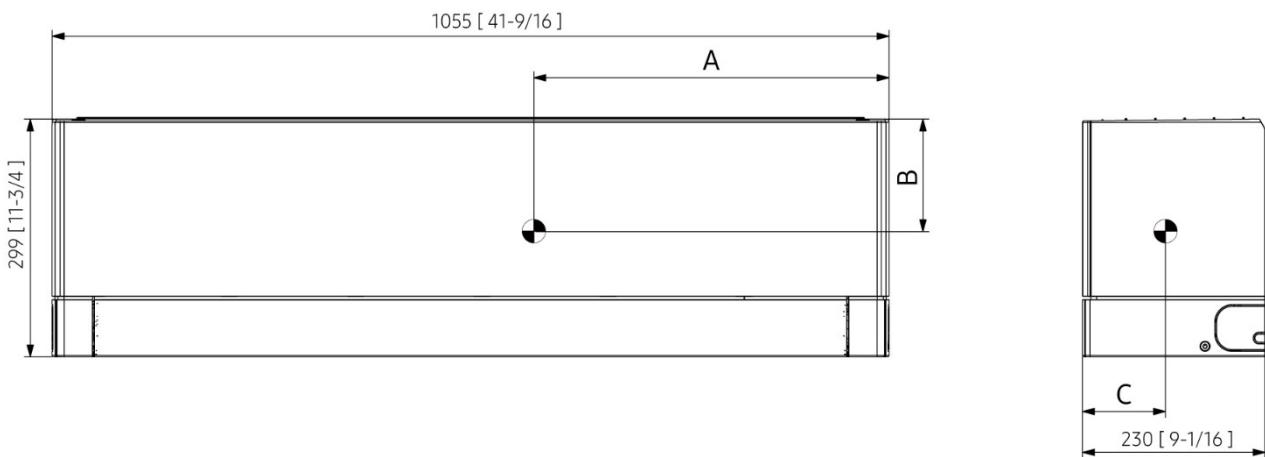

A	B	C
447.5[17-5/8]	153.5[6-1/16]	104.5[4-1/8]

6. Center of Gravity

Outdoor Unit

AR70H07C1AWXEU, AR70H09C1AWXEU, AR70H09CAAWXEU, AR70H12C1AWXEU, AR70H12CAAWXEU
AR70H15C1AWXEU

Unit: mm [inch]

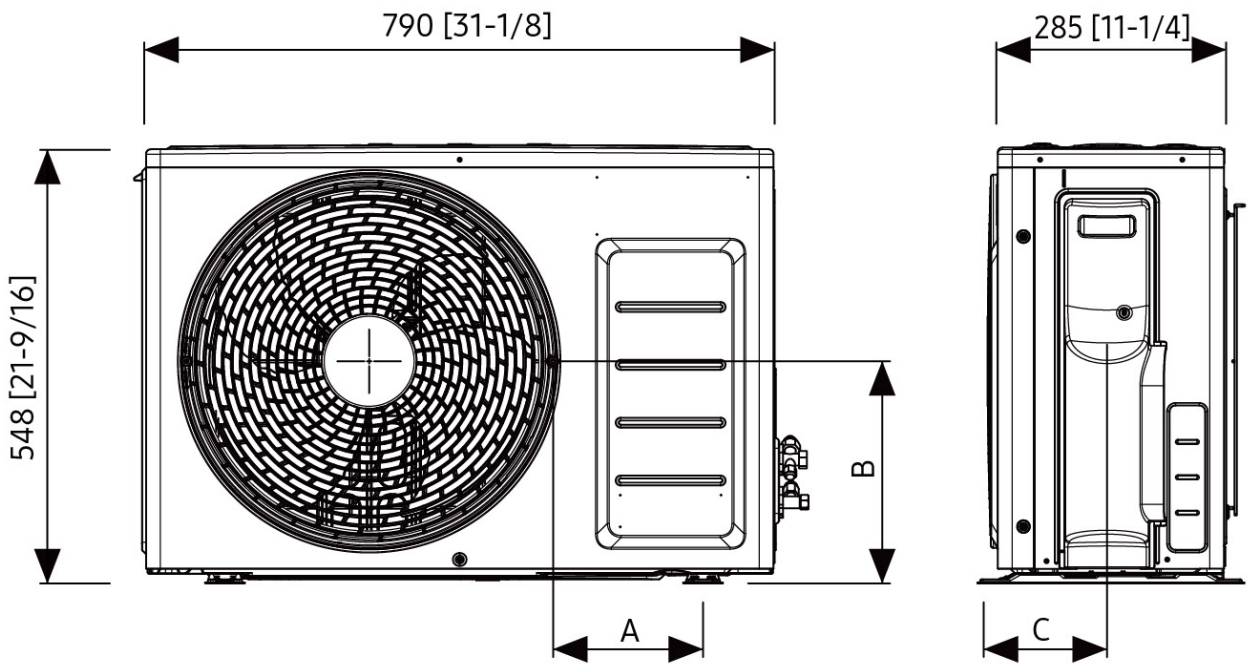

Model	A	B	C
AR70H07C1AWXEU AR70H09C1AWXEU AR70H09CAAWXEU AR70H12C1AWXEU AR70H12CAAWXEU AR70H15C1AWXEU	189[7-7/16]	279[11]	155[6-1/8]

6. Center of Gravity

Outdoor Unit

AR70H18C1AWXEU, AR70H24C1AWXEU

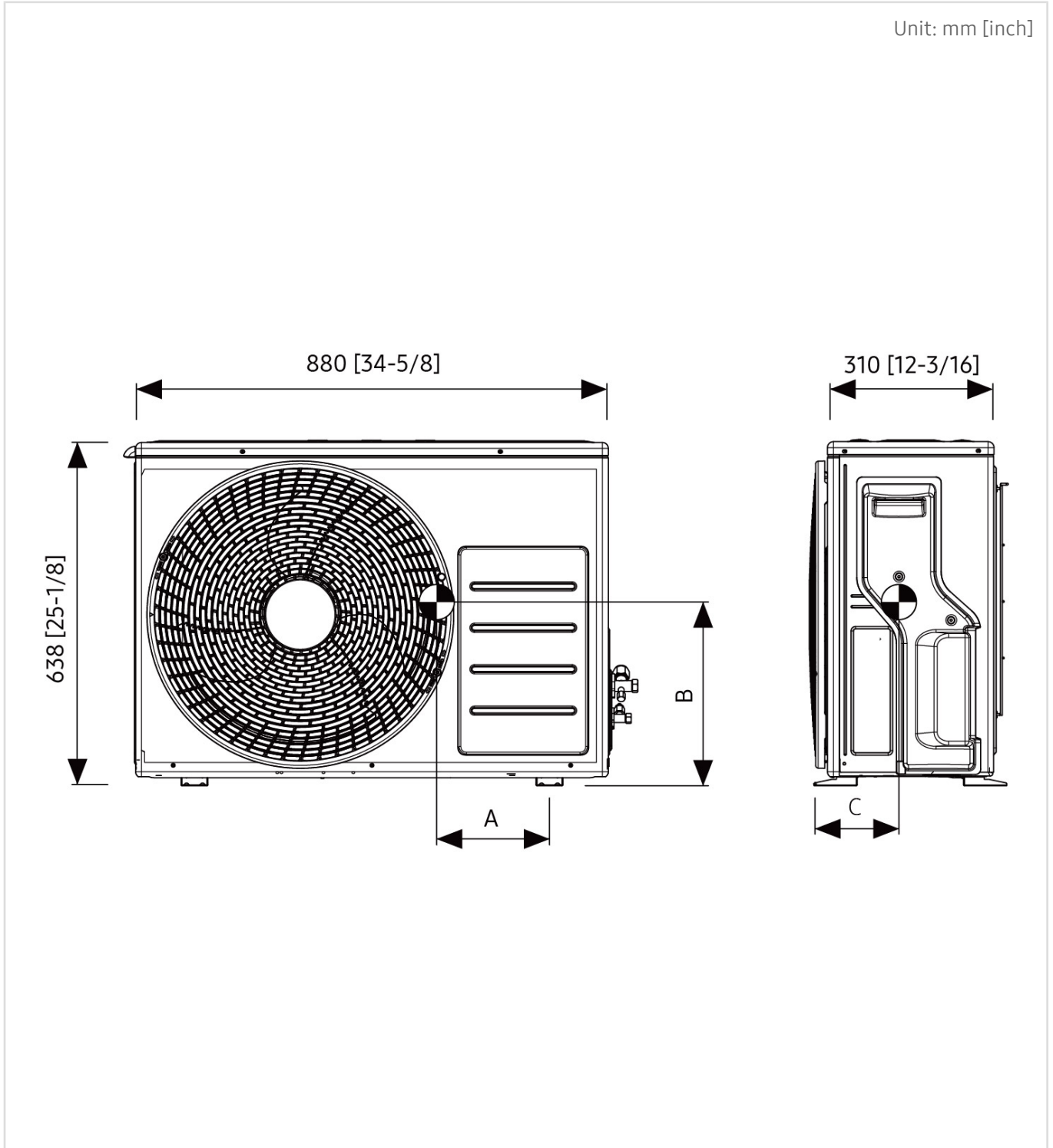

Model	A	B	C
AR70H18C1AWXEU AR70H24C1AWXEU	210[8-1/4]	341[13-7/16]	156[6-1/8]

7. Electrical Wiring Diagram

Indoor units

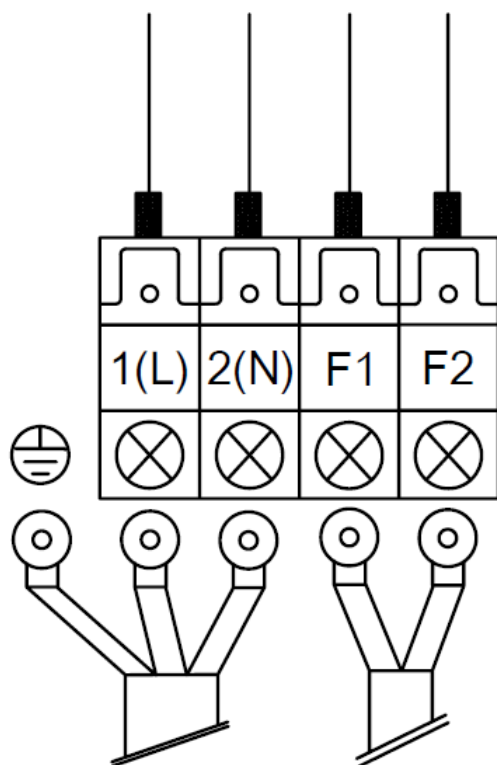

OPTION			
1(L)	2(N)	F1	F2
L1	L2	F1	F2

TERMINAL BLOCK	
1(L)/L1	POWER(L)
2(N)/L2	POWER(N)
F1	COMMUNICATION
F2	COMMUNICATION

USE COPPER SUPPLY WIRES
 UTILISER DES FILS
 D'ALIMENTATION EN CUIVRE
 (OPTION / USA&CANADA ONLY)

INDOOR-OUTDOOR POWER CABLE INDOOR-OUTDOOR COMM CABLE

NOTE

- This wiring diagram applies only to the indoor unit.
- Colors BRN : brown, GRN/YEL : green/yellow, RED : red, BLU : blue
- Ⓧ : Protective earth(screw)

7. Electrical Wiring Diagram

Outdoor Unit

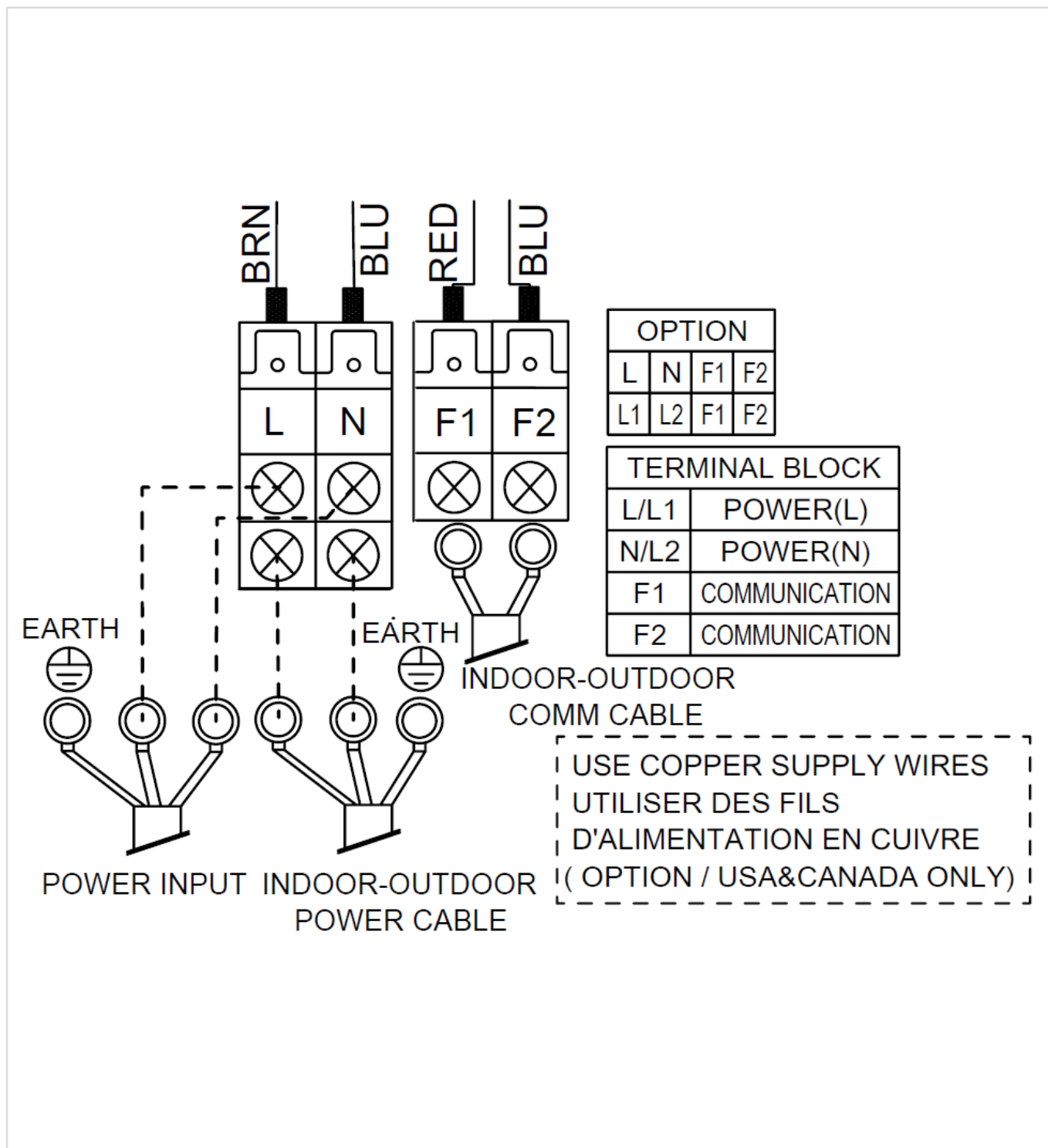

NOTE

- This wiring diagram applies only to the outdoor unit.
- Colors BRN : brown, GRN/YEL : green/yellow, RED : red, BLU : blue
- Ⓧ : Protective earth(screw)

8. Sound Data

Première Plus

Sound Pressure Level

Unit : dB(A)

Model	High	Silent
AR70H09CAAWNEU + AR70H09CAAWXEU	38	16
AR70H12CAAWNEU + AR70H12CAAWXEU	40	16

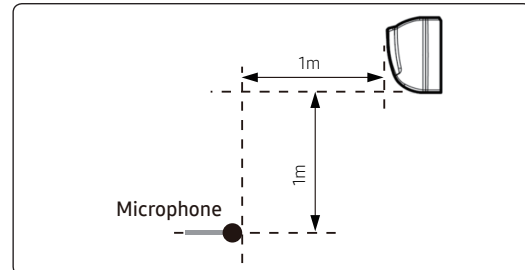

• NR CURVE

(1) AR70H09CAAWNEU + AR70H09CAAWXEU

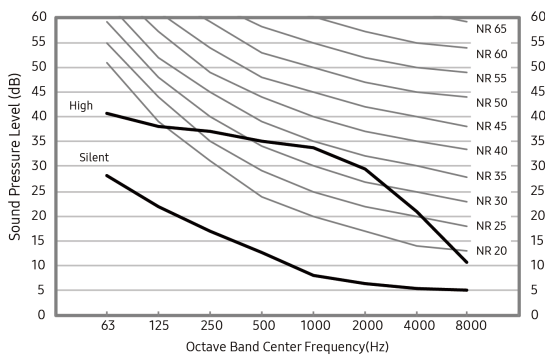

(2) AR70H12CAAWNEU + AR70H12CAAWXEU

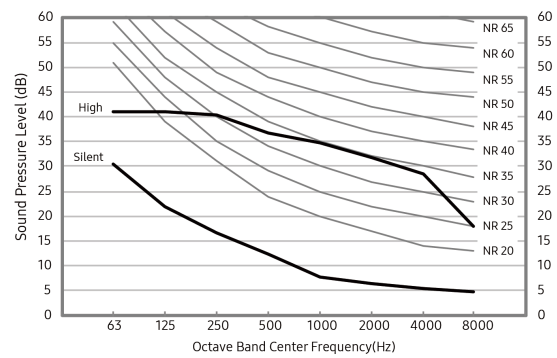

NOTE

- Specifications may be subject to change without prior notice.
- Sound power level is an absolute value that a sound source generates.
- dBA = A-weighted sound power level.
- Reference power : 1pW.
- Measured according to ISO 3741.

8. Sound Data

Première Plus Black

Sound Pressure Level

Unit : dB(A)

Model	High	Silent
AR70H09CAABNEU + AR70H09CAAWXEU	38	16
AR70H12CAABNEU + AR70H12CAAWXEU	40	16

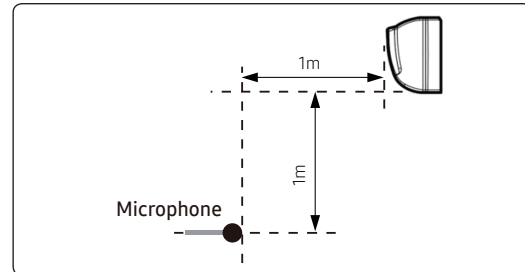

• NR CURVE

(1) AR70H09CAABNEU + AR70H09CAAWXEU

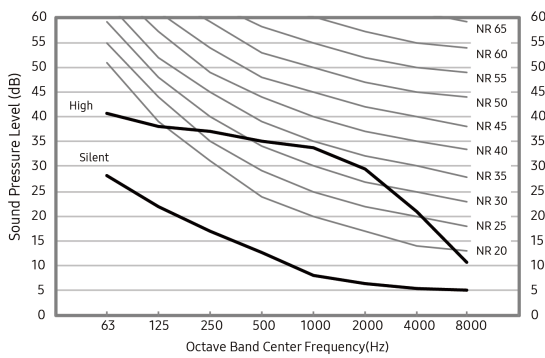

(2) AR70H12CAABNEU + AR70H12CAAWXEU

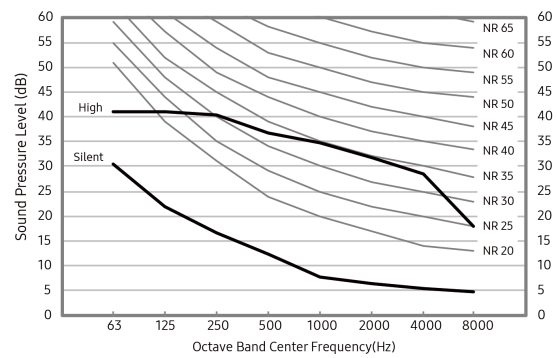

NOTE

- Specifications may be subject to change without prior notice.
- Sound power level is an absolute value that a sound source generates.
- dBA = A-weighted sound power level.
- Reference power : 1pW.
- Measured according to ISO 3741.

8. Sound Data

Première

Sound Pressure Level

Unit : dB(A)

Model	High	Silent
AR70H07C1AWNEU + AR70H07C1AWXEU	37	16
AR70H09C1AWNEU + AR70H09C1AWXEU	38	16
AR70H12C1AWNEU + AR70H12C1AWXEU	40	16
AR70H15C1AWNEU + AR70H15C1AWXEU	41	25

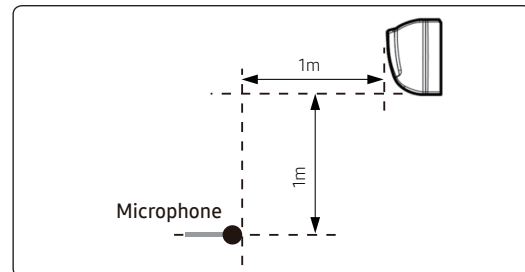

• NR CURVE

(1) AR70H07C1AWNEU + AR70H07C1AWXEU

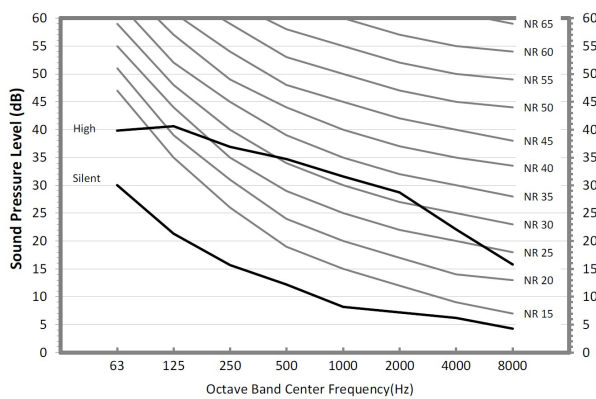

(2) AR70H09C1AWNEU + AR70H09C1AWXEU

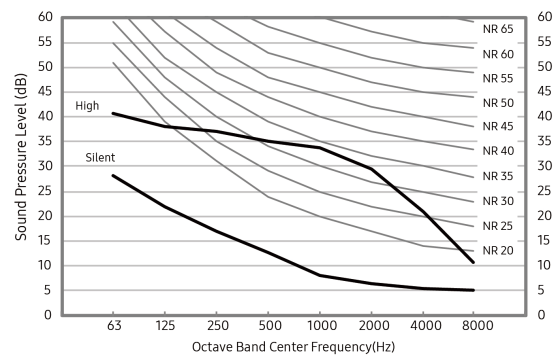

(3) AR70H12C1AWNEU + AR70H12C1AWXEU

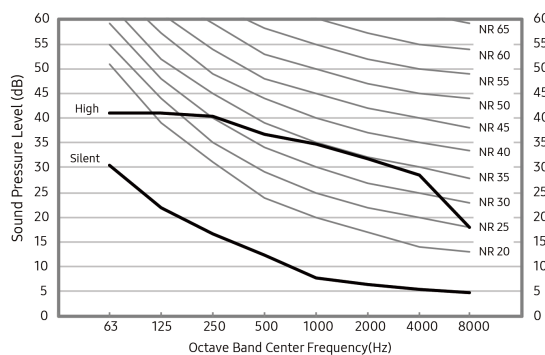

(4) AR70H15C1AWNEU + AR70H15C1AWXEU

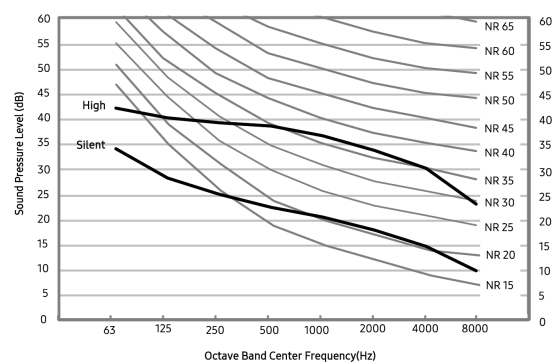

NOTE

- Specifications may be subject to change without prior notice.
- Sound power level is an absolute value that a sound source generates.
- dBA = A-weighted sound power level.
- Reference power : 1pW.
- Measured according to ISO 3741.

8. Sound Data

Première

Sound Pressure Level

Unit : dB(A)

Model	High	Silent
AR70H18C1AWNEU + AR70H18C1AWXEU	41	25
AR70H24C1AWNEU + AR70H24C1AWXEU	45	27

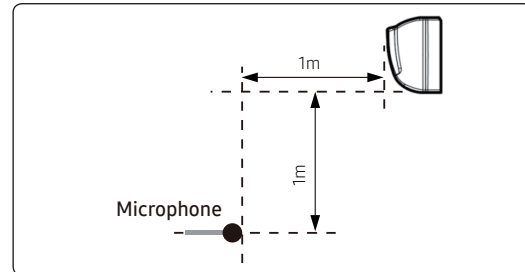

• NR CURVE

(1) AR70H18C1AWNEU + AR70H18C1AWXEU

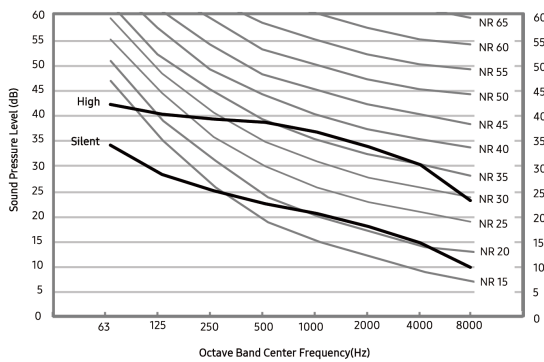

(2) AR70H24C1AWNEU + AR70H24C1AWXEU

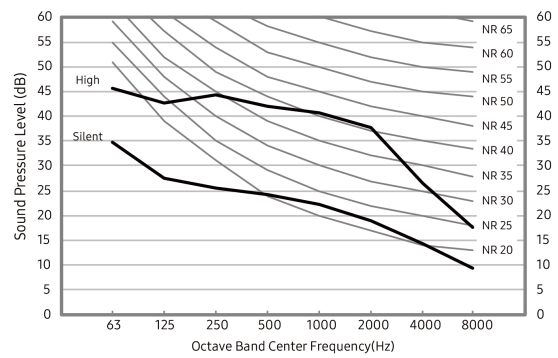

NOTE

- Specifications may be subject to change without prior notice.
- Sound power level is an absolute value that a sound source generates.
- dBA = A-weighted sound power level.
- Reference power : 1pW.
- Measured according to ISO 3741.

8. Sound Data

Première Black

Sound Pressure Level

Unit : dB(A)

Model	High	Silent
AR70H07C1ABNEU + AR70H07C1AWXEU	37	16
AR70H09C1ABNEU + AR70H09C1AWXEU	38	16
AR70H12C1ABNEU + AR70H12C1AWXEU	40	16

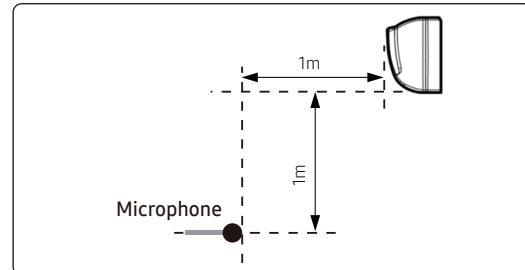

• NR CURVE

(1) AR70H07C1ABNEU + AR70H07C1AWXEU

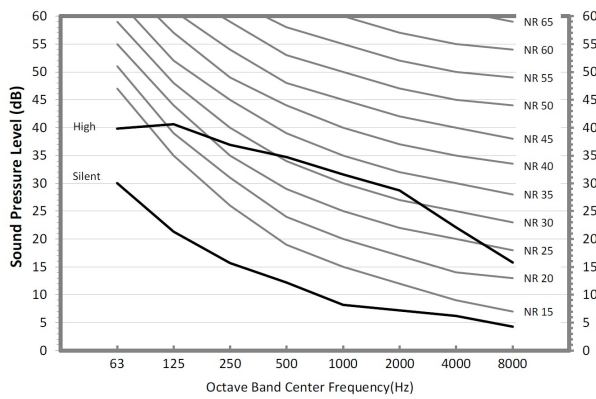

(2) AR70H09C1ABNEU + AR70H09C1AWXEU

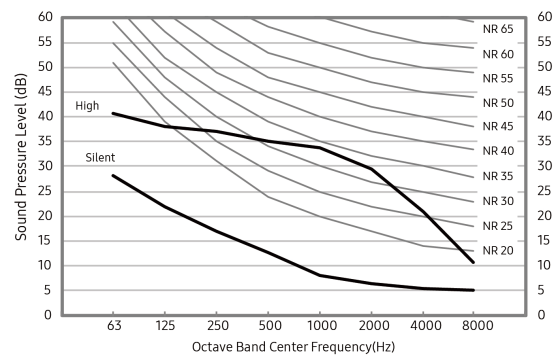

(3) AR70H12C1ABNEU + AR70H12C1AWXEU

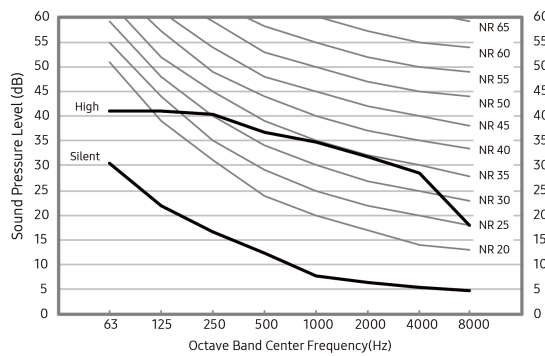

NOTE

- Specifications may be subject to change without prior notice.
- Sound power level is an absolute value that a sound source generates.
- dBA = A-weighted sound power level.
- Reference power : 1pW.
- Measured according to ISO 3741.

8. Sound Data

Outdoor Unit

Sound Pressure Level

Unit : dB(A)

Model	Cooling
AR70H09CAAWXEU	45
AR70H12CAAWXEU	46
AR70H07C1AWXEU	45
AR70H09C1AWXEU	45

• NR CURVE

(1) AR70H09CAAWXEU

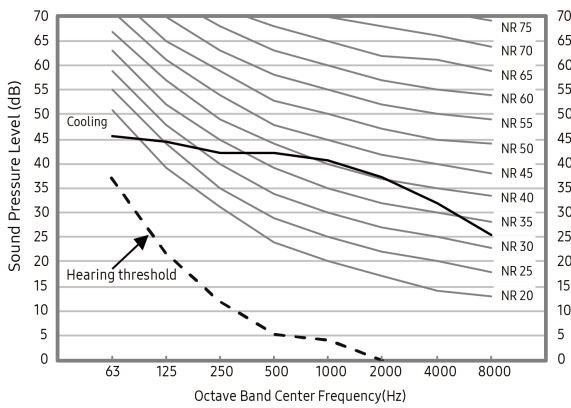

(2) AR70H12CAAWXEU

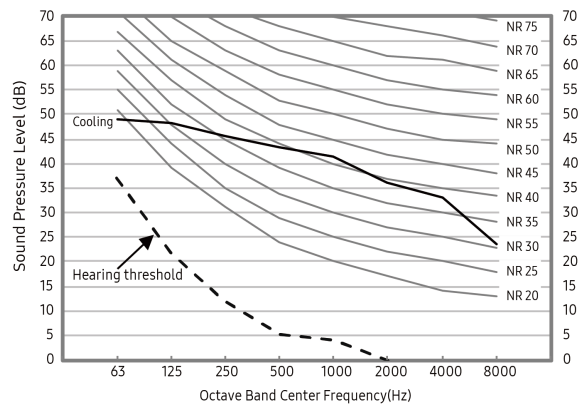

(3) AR70H07C1AWXEU

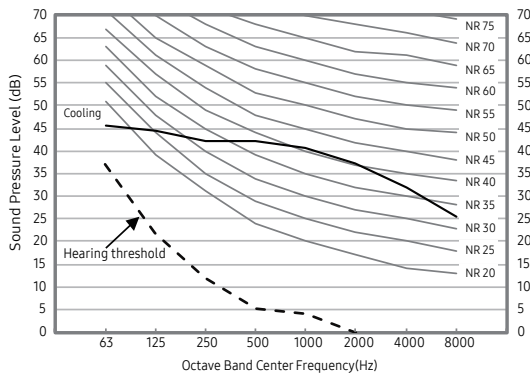

(4) AR70H09C1AWXEU

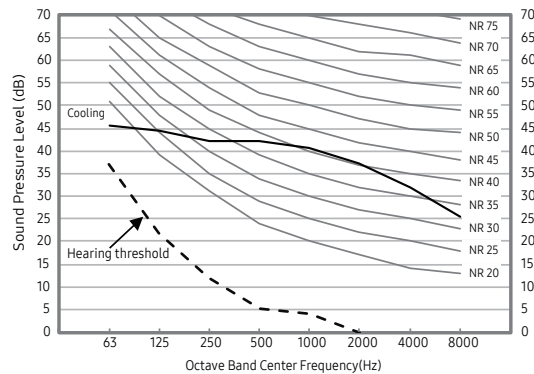

NOTE

- Specifications may be subject to change without prior notice.
- Sound power level is an absolute value that a sound source generates.
- dBA = A-weighted sound power level.
- Reference power : 1pW.
- Measured according to ISO 3741.

8. Sound Data

Outdoor Unit

Sound Pressure Level

Unit : dB(A)

Model	Cooling
AR70H12C1AWXEU	46
AR70H15C1AWXEU	48
AR70H18C1AWXEU	51
AR70H24C1AWXEU	54

• NR CURVE

(1) AR70H12C1AWXEU

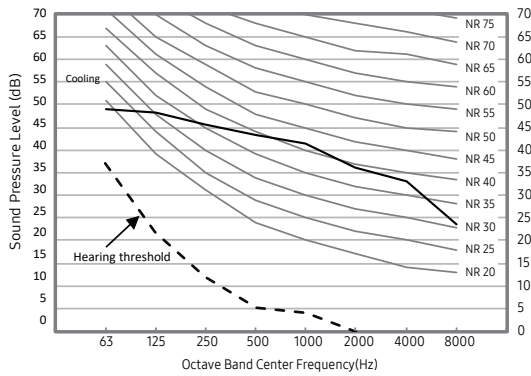

(2) AR70H15C1AWXEU

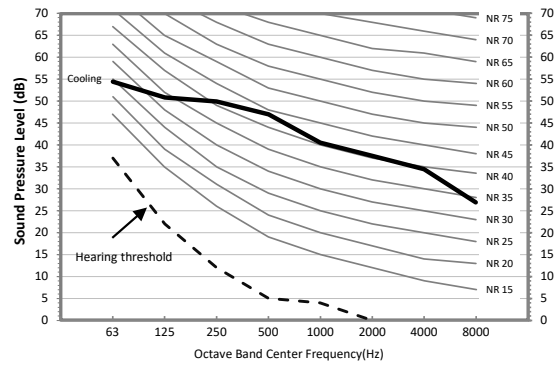

(3) AR70H18C1AWXEU

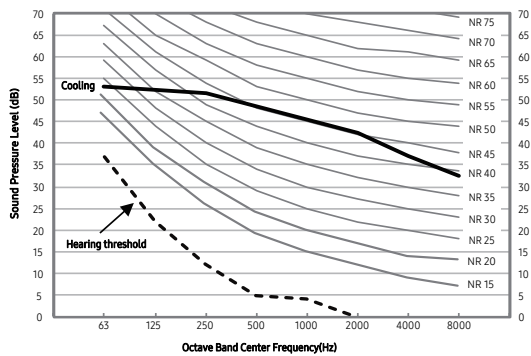

(4) AR70H24C1AWXEU

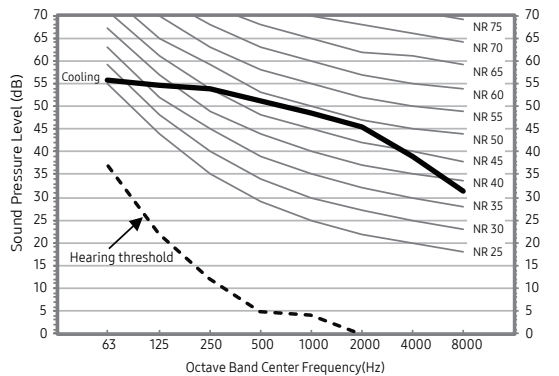

NOTE

- Specifications may be subject to change without prior notice.
- Sound power level is an absolute value that a sound source generates.
- dBA = A-weighted sound power level.
- Reference power : 1pW.
- Measured according to ISO 3741.

8. Sound Data

Première Plus

Sound Power Level

Unit : dB(A)

Model	Cooling
AR70H09CAAWNEU + AR70H09CAAWXEU	56
AR70H12CAAWNEU + AR70H12CAAWXEU	58

• NR CURVE

(1) AR70H09CAAWNEU + AR70H09CAAWXEU

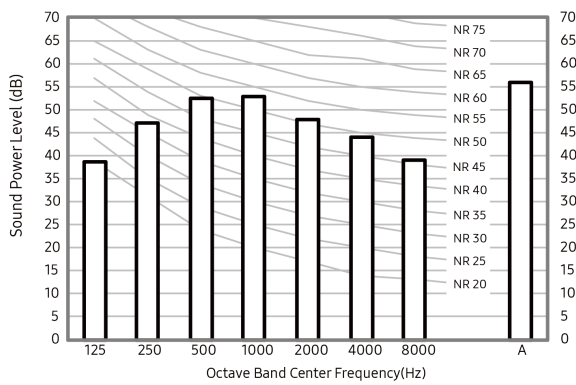

(2) AR70H12CAAWNEU + AR70H12CAAWXEU

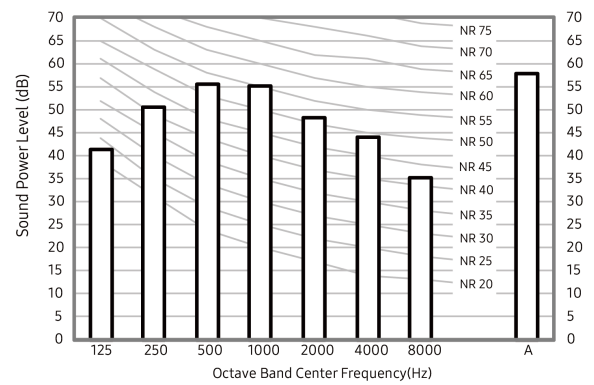

NOTE

- Specifications may be subject to change without prior notice.
- Sound power level is an absolute value that a sound source generates.
- dBA = A-weighted sound power level.
- Reference power : 1pW.
- Measured according to ISO 3741.

8. Sound Data

Première Plus Black

Sound Power Level

Unit : dB(A)

Model	Cooling
AR70H09CAABNEU + AR70H09CAAWXEU	56
AR70H12CAABNEU + AR70H12CAAWXEU	58

• NR CURVE

(1) AR70H09CAABNEU + AR70H09CAAWXEU

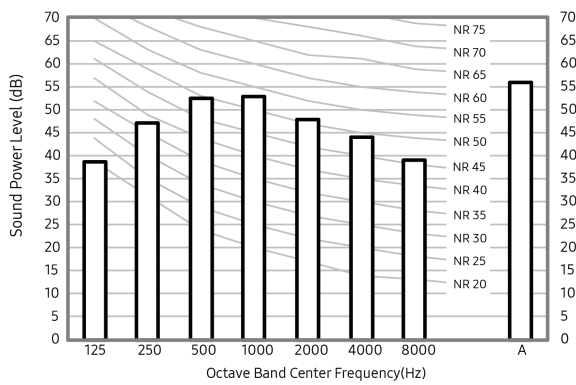

(2) AR70H12CAABNEU + AR70H12CAAWXEU

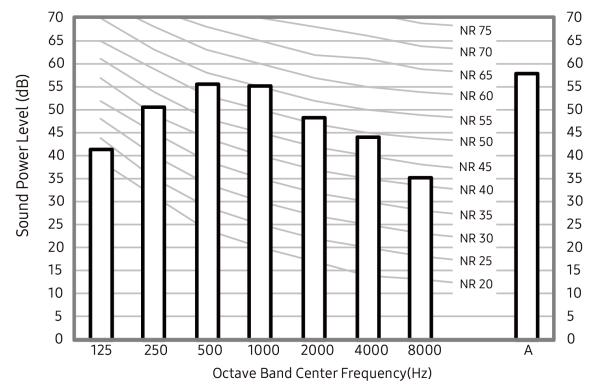

NOTE

- Specifications may be subject to change without prior notice.
- Sound power level is an absolute value that a sound source generates.
- dBA = A-weighted sound power level.
- Reference power : 1pW.
- Measured according to ISO 3741.

8. Sound Data

Première

Sound Power Level

Unit : dB(A)

Model	Cooling
AR70H07C1AWNEU + AR70H07C1AWXEU	56
AR70H09C1AWNEU + AR70H09C1AWXEU	56
AR70H12C1AWNEU + AR70H12C1AWXEU	58
AR70H15C1AWNEU + AR70H15C1AWXEU	58

• NR CURVE

(1) AR70H07C1AWNEU + AR70H07C1AWXEU

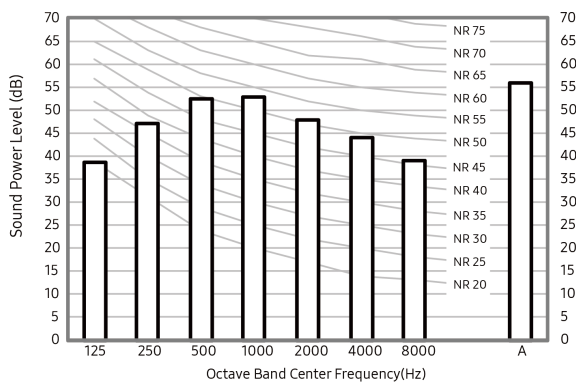

(2) AR70H09C1AWNEU + AR70H09C1AWXEU

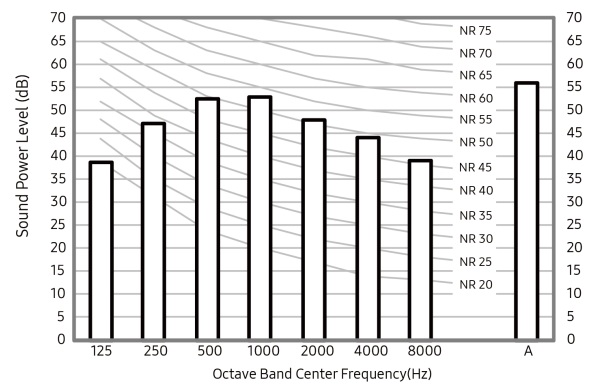

(3) AR70H12C1AWNEU + AR70H12C1AWXEU

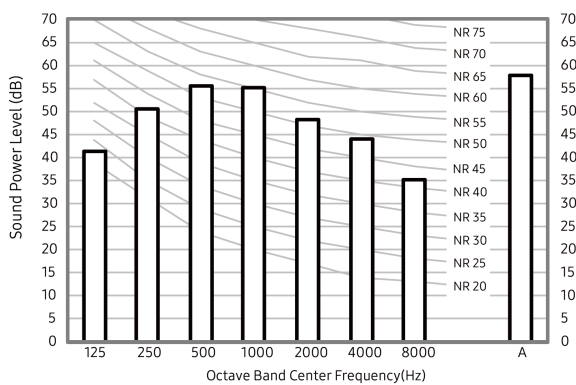

(4) AR70H15C1AWNEU + AR70H15C1AWXEU

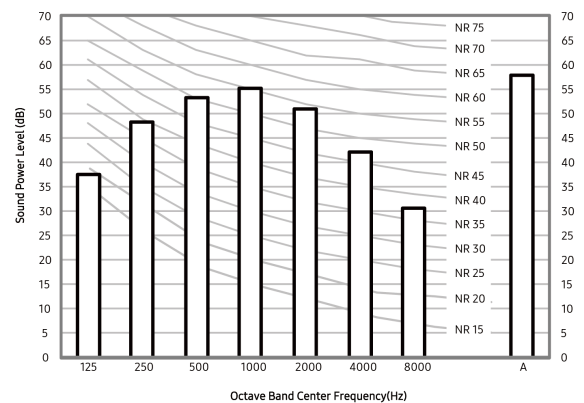

NOTE

- Specifications may be subject to change without prior notice.
- Sound power level is an absolute value that a sound source generates.
- dBA = A-weighted sound power level.
- Reference power : 1pW.
- Measured according to ISO 3741.

8. Sound Data

Première

Sound Power Level

Unit : dB(A)

Model	Cooling
AR70H18C1AWNEU + AR70H18C1AWXEU	58
AR70H24C1AWNEU + AR70H24C1AWXEU	62

• NR CURVE

(1) AR70H18C1AWNEU + AR70H18C1AWXEU

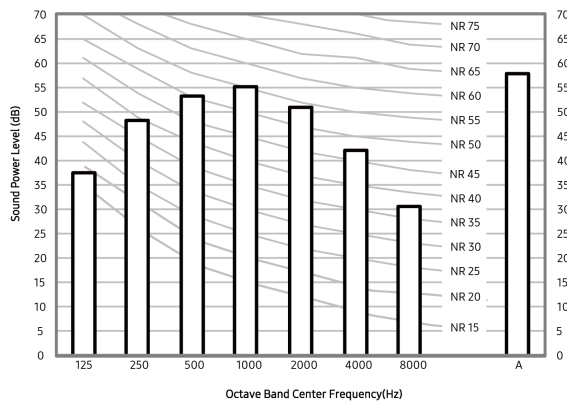

(2) AR70H24C1AWNEU + AR70H24C1AWXEU

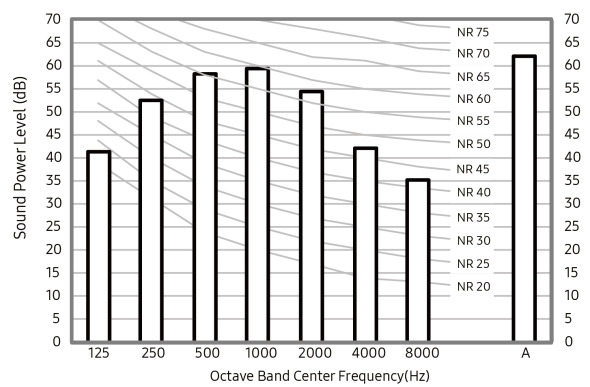

NOTE

- Specifications may be subject to change without prior notice.
- Sound power level is an absolute value that a sound source generates.
- dBA = A-weighted sound power level.
- Reference power : 1pW.
- Measured according to ISO 3741.

8. Sound Data

Première Black

Sound Power Level

Unit : dB(A)

Model	Cooling
AR70H07C1ABNEU + AR70H07C1AWXEU	56
AR70H09C1ABNEU + AR70H09C1AWXEU	56
AR70H12C1ABNEU + AR70H12C1AWXEU	58

• NR CURVE

(1) AR70H07C1ABNEU + AR70H07C1AWXEU

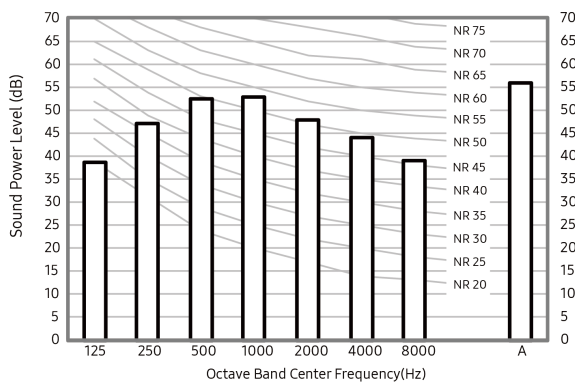

(2) AR70H09C1ABNEU + AR70H09C1AWXEU

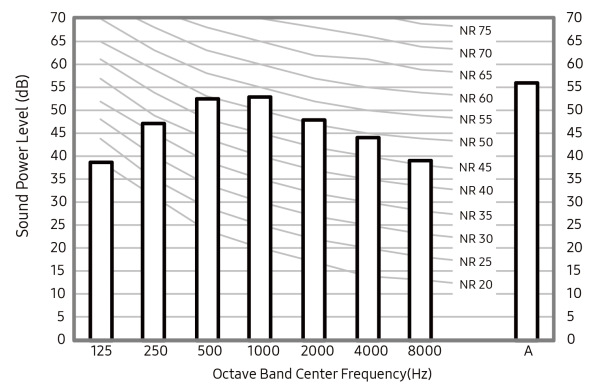

(3) AR70H12C1ABNEU + AR70H12C1AWXEU

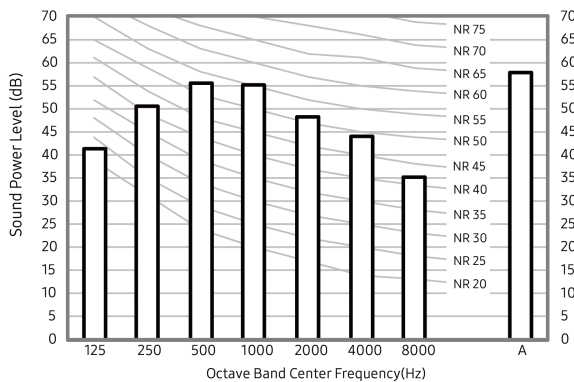

NOTE

- Specifications may be subject to change without prior notice.
- Sound power level is an absolute value that a sound source generates.
- dBA = A-weighted sound power level.
- Reference power : 1pW.
- Measured according to ISO 3741.

8. Sound Data

Outdoor Unit

Sound Power Level

Unit : dB(A)

Model	Cooling
AR70H09CAAWXEU	59
AR70H12CAAWXEU	62
AR70H07C1AWXEU	59
AR70H09C1AWXEU	59

• NR CURVE

(1) AR70H09CAAWXEU

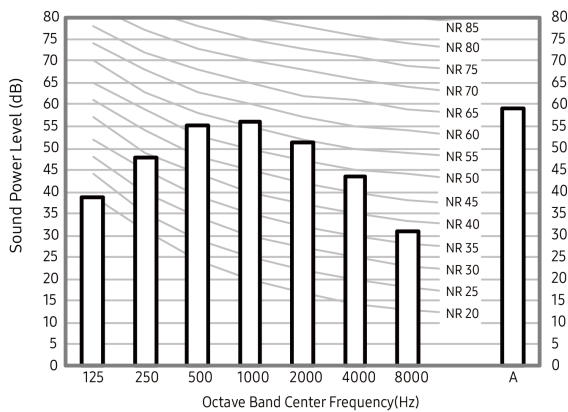

(2) AR70H12CAAWXEU

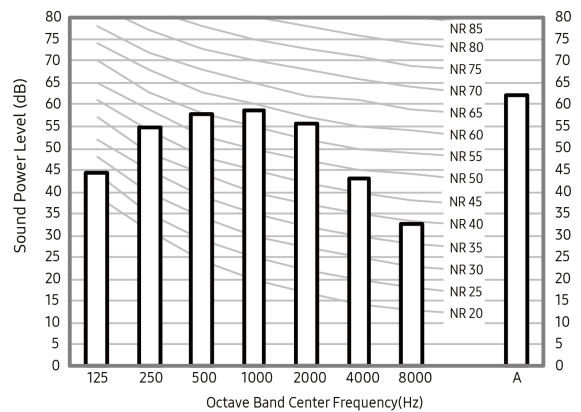

(3) AR70H07C1AWXEU

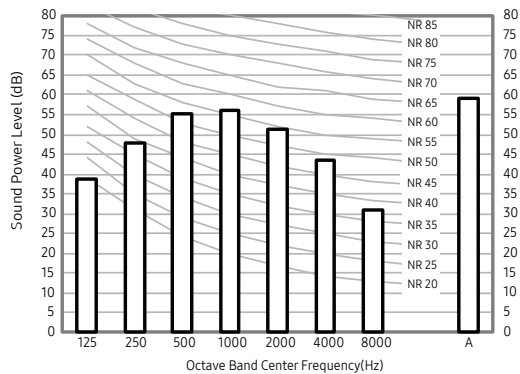

(4) AR70H09C1AWXEU

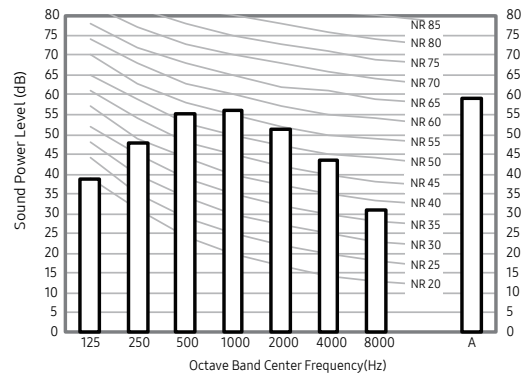

NOTE

- Specifications may be subject to change without prior notice.
- Sound power level is an absolute value that a sound source generates.
- dBA = A-weighted sound power level.
- Reference power : 1pW.
- Measured according to ISO 3741.

8. Sound Data

Outdoor Unit

Sound Power Level

Unit : dB(A)

Model	Cooling
AR70H12C1AWXEU	62
AR70H15C1AWXEU	65
AR70H07C1AWXEU	65
AR70H09C1AWXEU	68

• NR CURVE

(1) AR70H12C1AWXEU

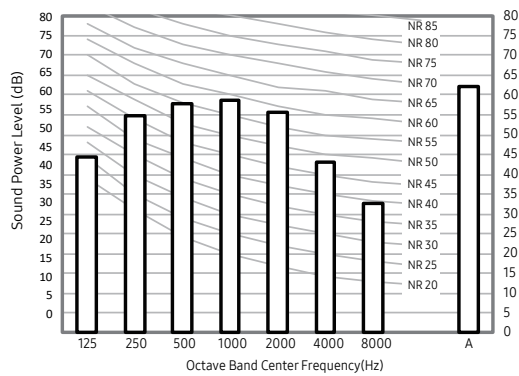

(2) AR70H15C1AWXEU

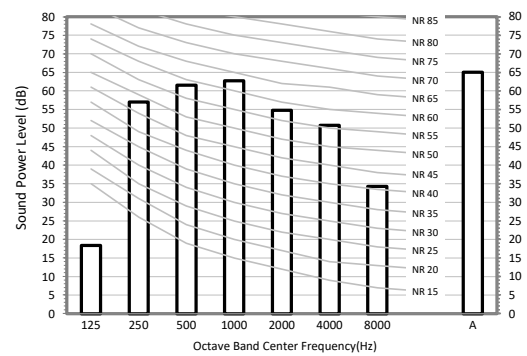

(3) AR70H18C1AWXEU

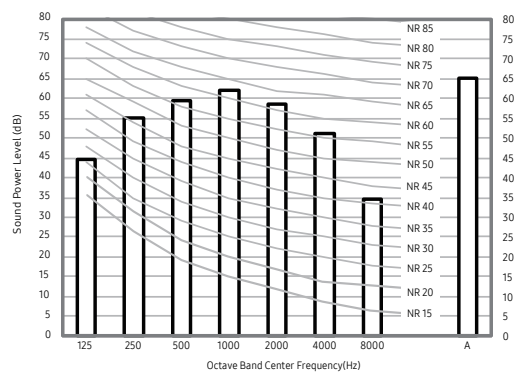

(4) AR70H24C1AWXEU

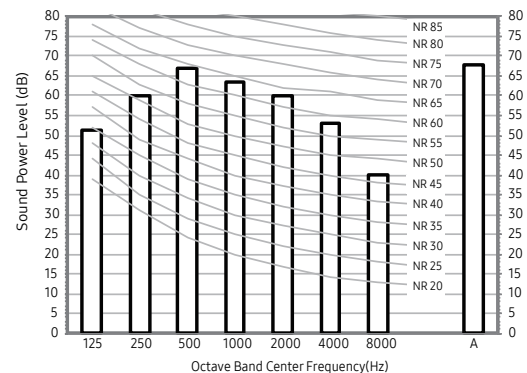

NOTE

- Specifications may be subject to change without prior notice.
- Sound power level is an absolute value that a sound source generates.
- dBA = A-weighted sound power level.
- Reference power : 1pW.
- Measured according to ISO 3741.

9. Temperature and Air Flow Distribution

Première Plus

AR70H09CAAWNEU + AR70H09CAAWXEU

- Cooling AirVelocity Distribution (Discharge Angle : 25 degree)

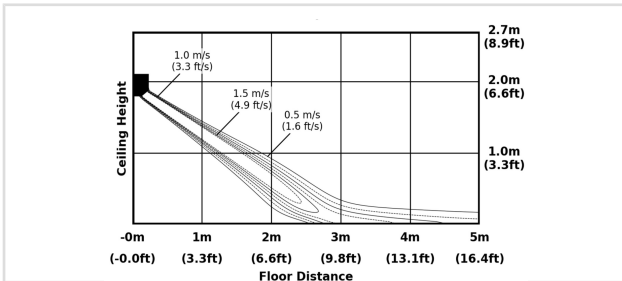

- Cooling Temperature Distribution (Discharge Angle : 25 degree)

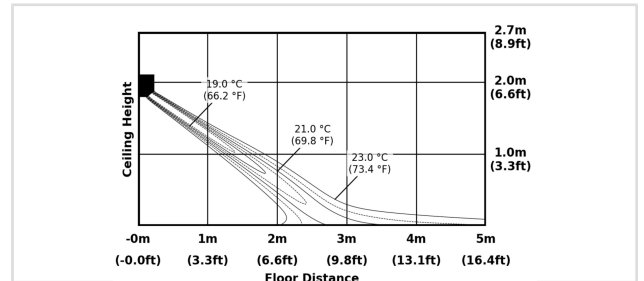

- Heating AirVelocity Distribution (Discharge Angle : 45 degree)

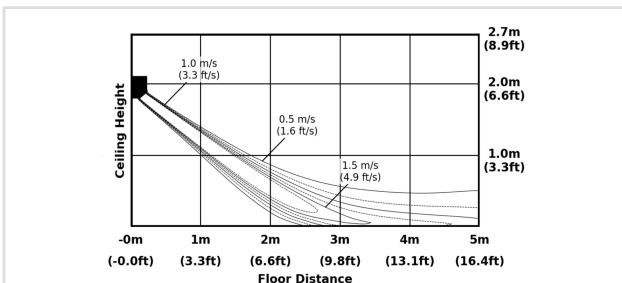

- Heating Temperature Distribution (Discharge Angle : 45 degree)

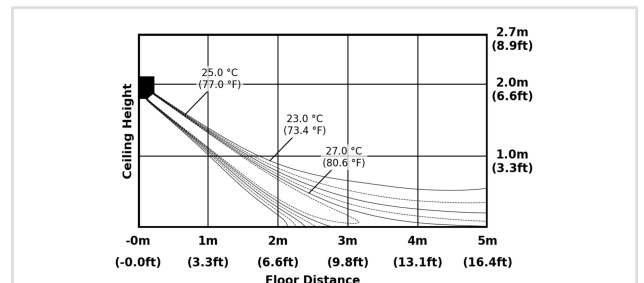

AR70H12CAAWNEU + AR70H12CAAWXEU

- Cooling AirVelocity Distribution (Discharge Angle : 25 degree)

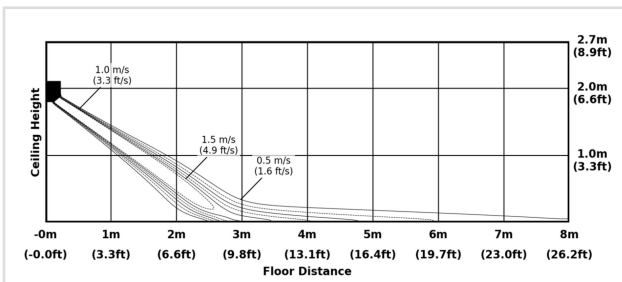

- Cooling Temperature Distribution (Discharge Angle : 25 degree)

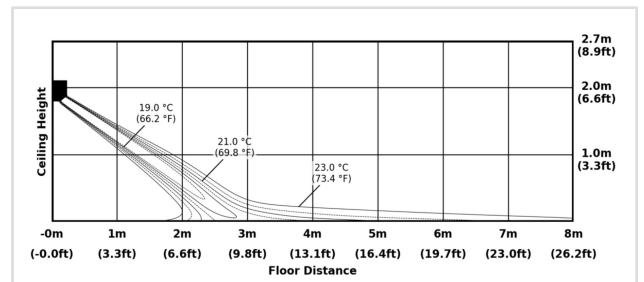

- Heating AirVelocity Distribution (Discharge Angle : 45 degree)

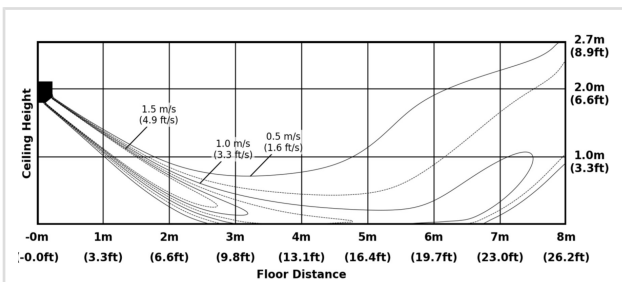

- Heating Temperature Distribution (Discharge Angle : 45 degree)

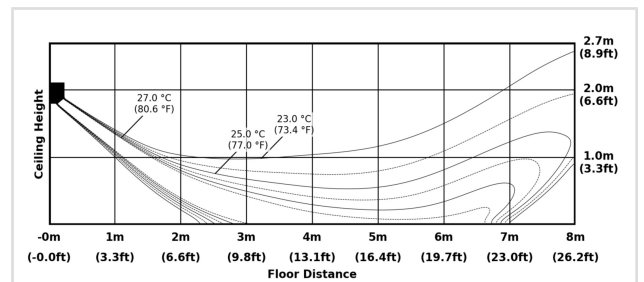

9. Temperature and Air Flow Distribution

Première Plus Black

AR70H09CAABNEU + AR70H09CAAWXEU

- Cooling AirVelocity Distribution (Discharge Angle : 25 degree)

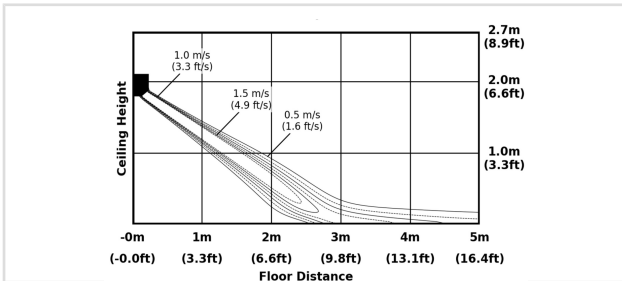

- Cooling Temperature Distribution (Discharge Angle : 25 degree)

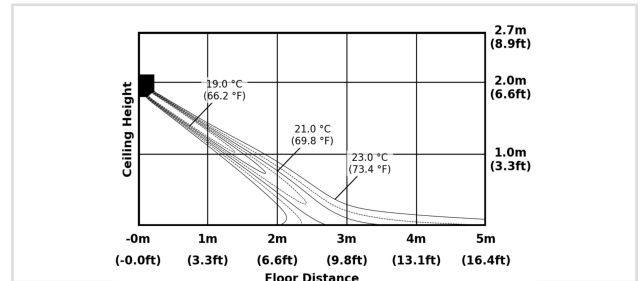

- Heating AirVelocity Distribution (Discharge Angle : 45 degree)

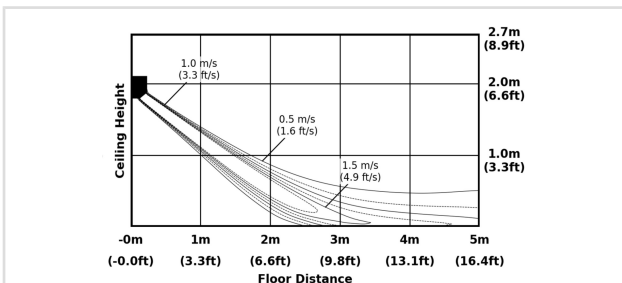

- Heating Temperature Distribution (Discharge Angle : 45 degree)

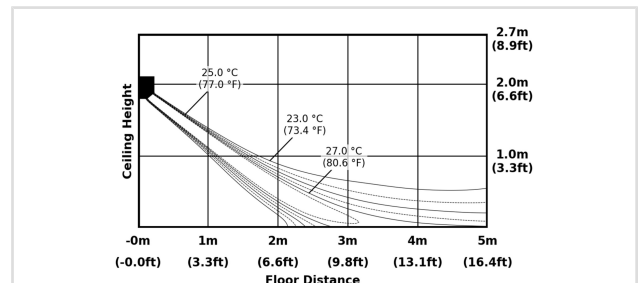

AR70H12CAABNEU + AR70H12CAAWXEU

- Cooling AirVelocity Distribution (Discharge Angle : 25 degree)

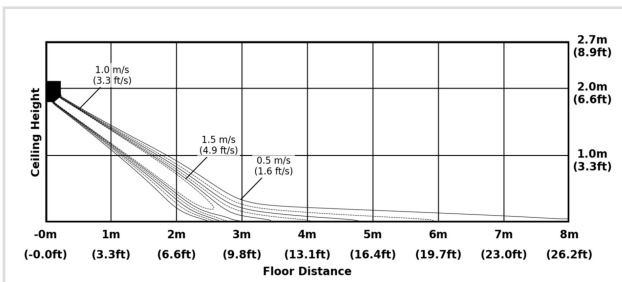

- Cooling Temperature Distribution (Discharge Angle : 25 degree)

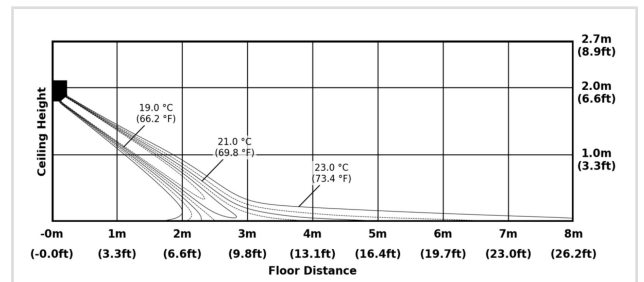

- Heating AirVelocity Distribution (Discharge Angle : 45 degree)

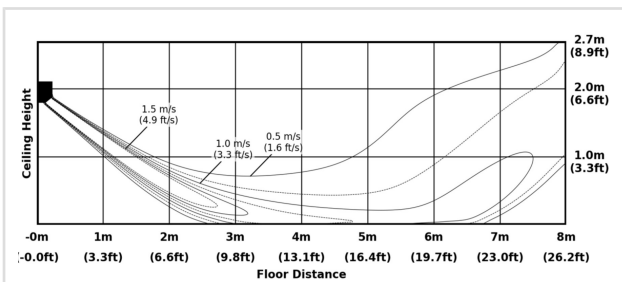

- Heating Temperature Distribution (Discharge Angle : 45 degree)

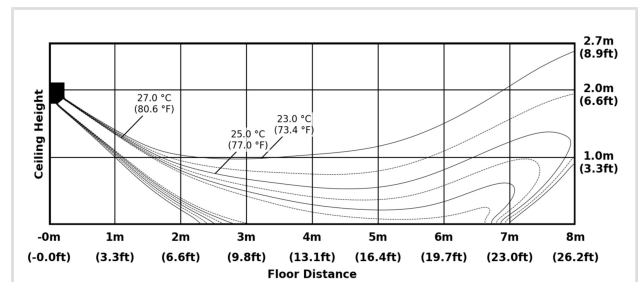

9. Temperature and Air Flow Distribution

Première

AR70H07C1AWNEU + AR70H07C1AWXEU

- Cooling Air Velocity Distribution (Discharge Angle : 25 degree)

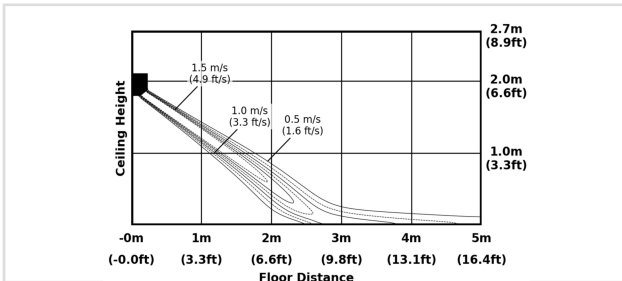

- Cooling Temperature Distribution (Discharge Angle : 25 degree)

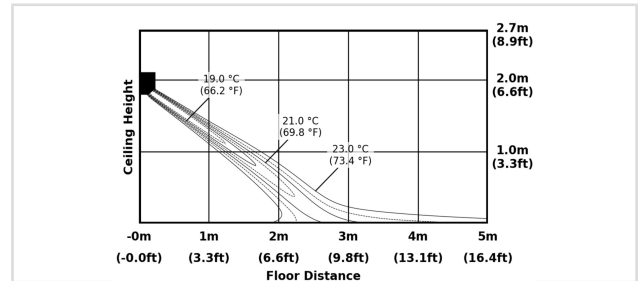

- Heating Air Velocity Distribution (Discharge Angle : 45 degree)

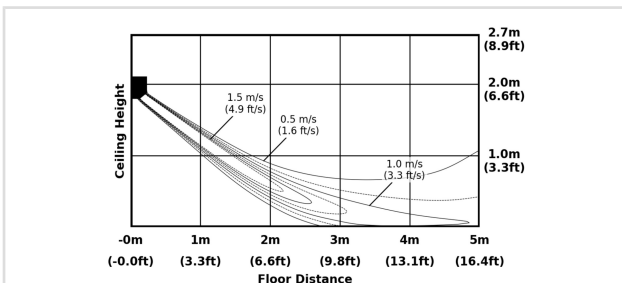

- Heating Temperature Distribution (Discharge Angle : 45 degree)

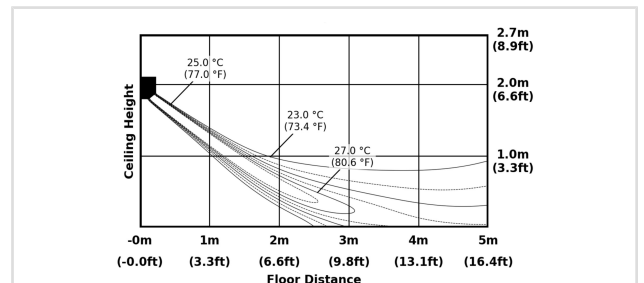

AR70H09C1AWNEU + AR70H09C1AWXEU

- Cooling Air Velocity Distribution (Discharge Angle : 25 degree)

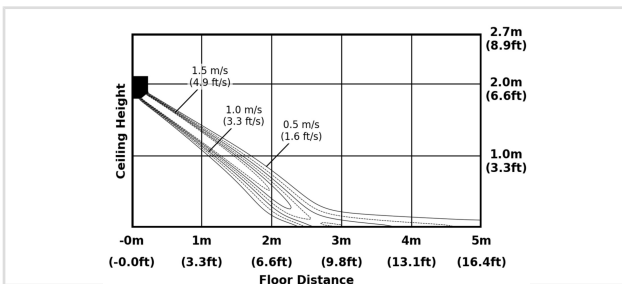

- Cooling Temperature Distribution (Discharge Angle : 25 degree)

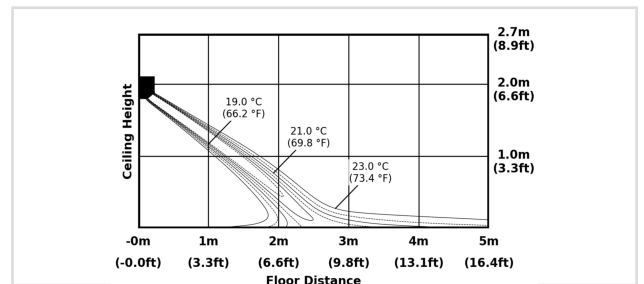

- Heating Air Velocity Distribution (Discharge Angle : 45 degree)

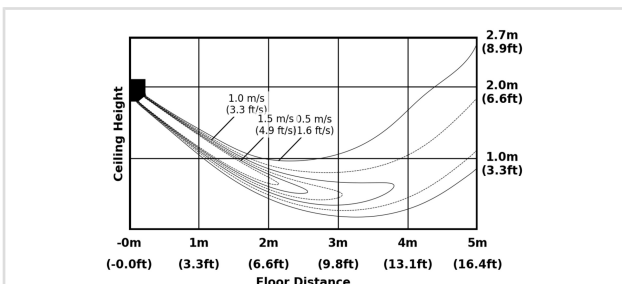

- Heating Temperature Distribution (Discharge Angle : 45 degree)

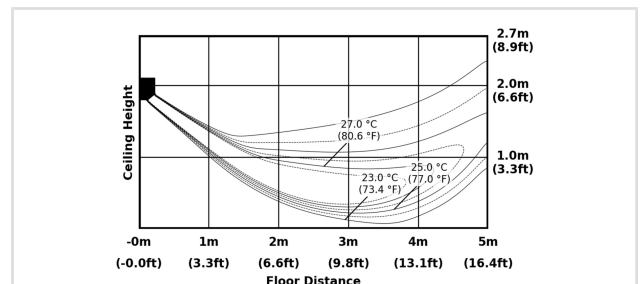

9. Temperature and Air Flow Distribution

Première

AR70H12C1AWNEU + AR70H12C1AWXEU

- Cooling AirVelocity Distribution (Discharge Angle : 25 degree)

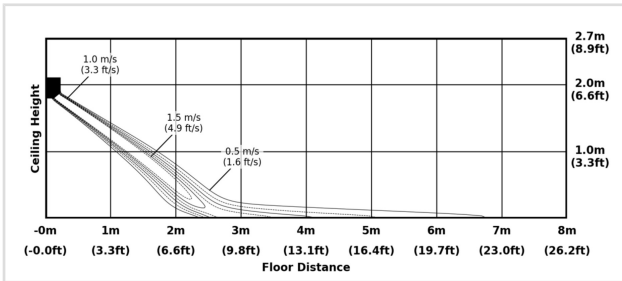

- Cooling Temperature Distribution (Discharge Angle : 25 degree)

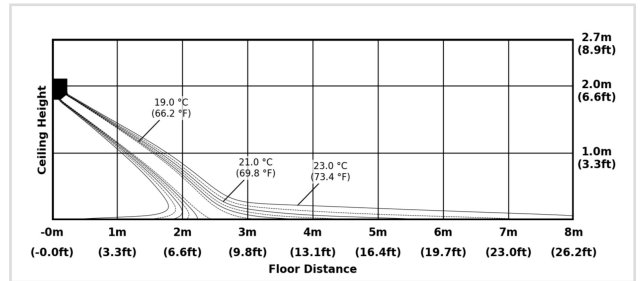

- Heating AirVelocity Distribution (Discharge Angle : 45 degree)

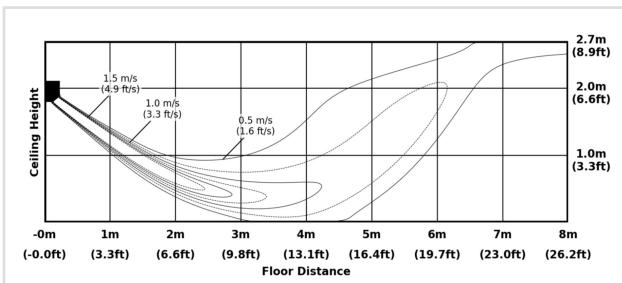

- Heating Temperature Distribution (Discharge Angle : 45 degree)

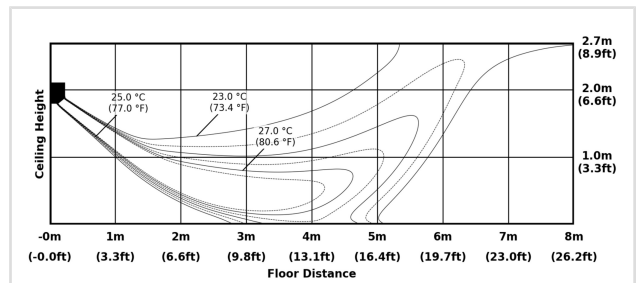

AR70H15C1AWNEU + AR70H15C1AWXEU

- Cooling AirVelocity Distribution (Discharge Angle : 25 degree)

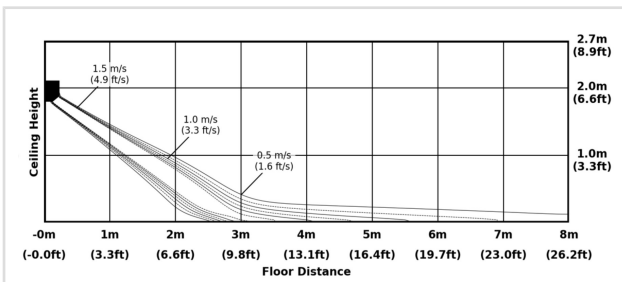

- Cooling Temperature Distribution (Discharge Angle : 25 degree)

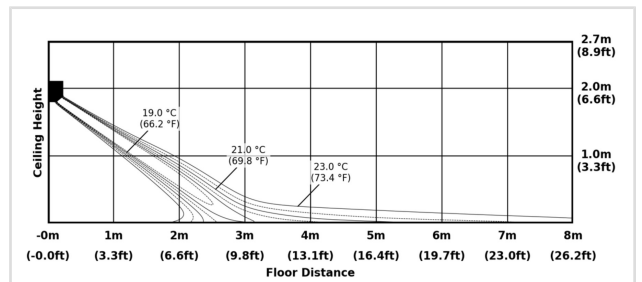

- Heating AirVelocity Distribution (Discharge Angle : 45 degree)

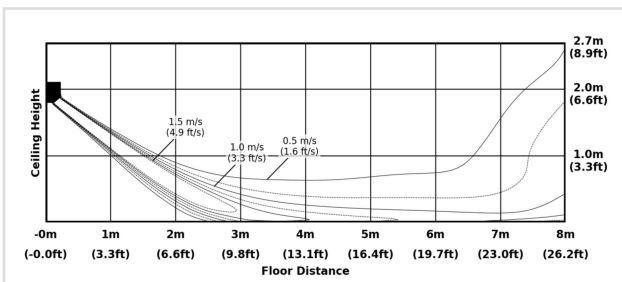

- Heating Temperature Distribution (Discharge Angle : 45 degree)

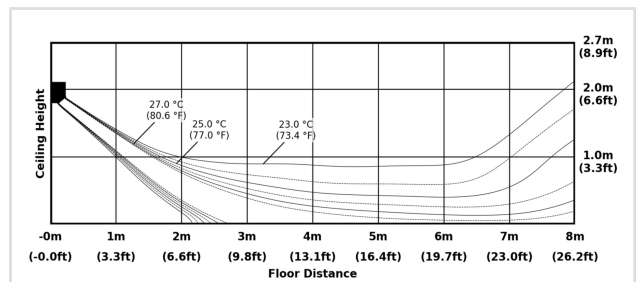

9. Temperature and Air Flow Distribution

Première

AR70H18C1AWNEU + AR70H18C1AWXEU

- Cooling AirVelocity Distribution (Discharge Angle : 25 degree)

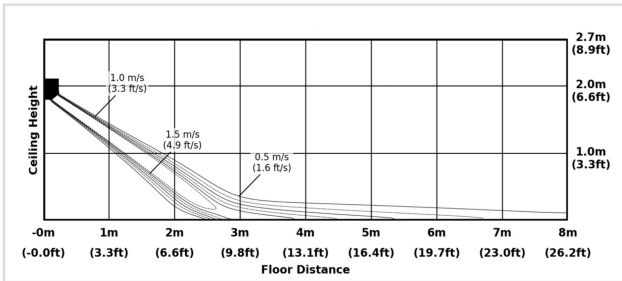

- Cooling Temperature Distribution (Discharge Angle : 25 degree)

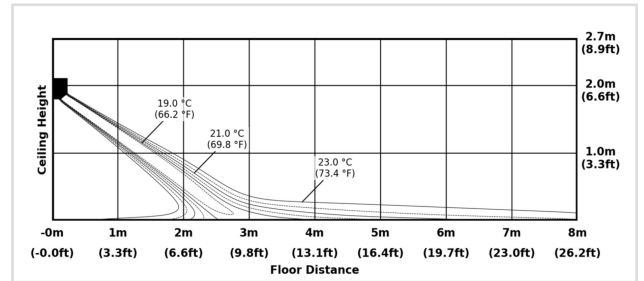

- Heating AirVelocity Distribution (Discharge Angle : 45 degree)

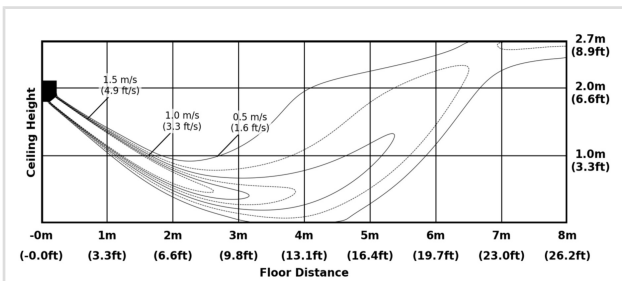

- Heating Temperature Distribution (Discharge Angle : 45 degree)

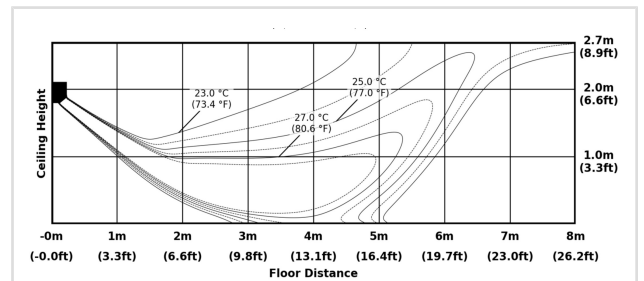

AR70H24C1AWNEU + AR70H24C1AWXEU

- Cooling AirVelocity Distribution (Discharge Angle : 25 degree)

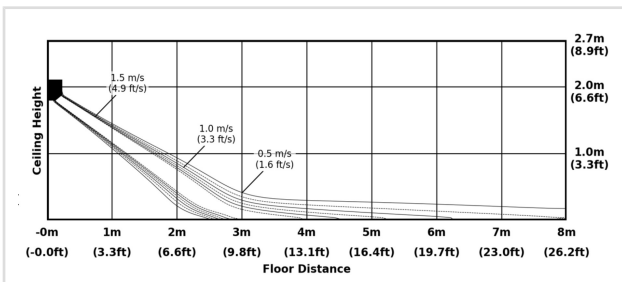

- Cooling Temperature Distribution (Discharge Angle : 25 degree)

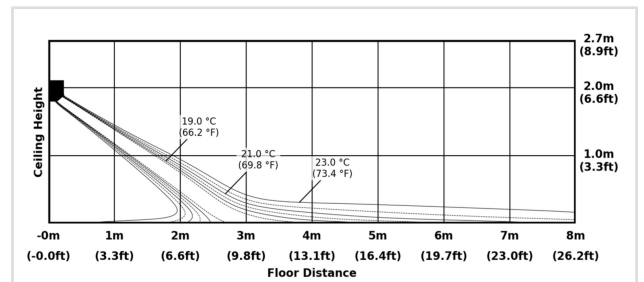

- Heating AirVelocity Distribution (Discharge Angle : 45 degree)

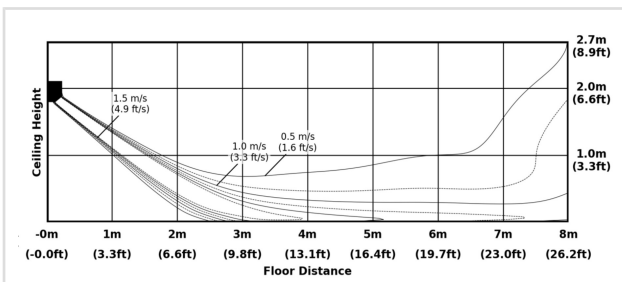

- Heating Temperature Distribution (Discharge Angle : 45 degree)

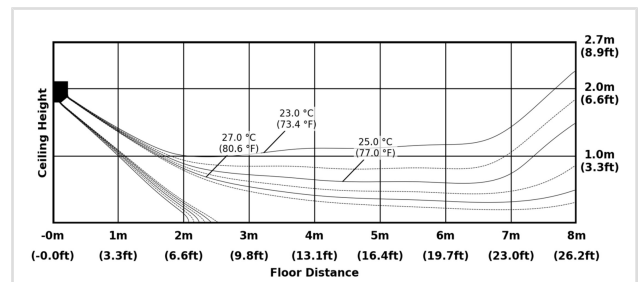

9. Temperature and Air Flow Distribution

Première Black

AR70H07C1ABNEU + AR70H07C1AWXEU

- Cooling AirVelocity Distribution (Discharge Angle : 25 degree)

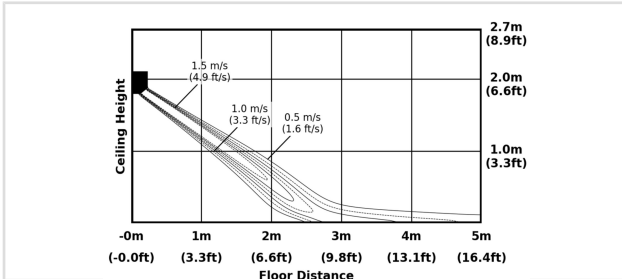

- Cooling Temperature Distribution (Discharge Angle : 25 degree)

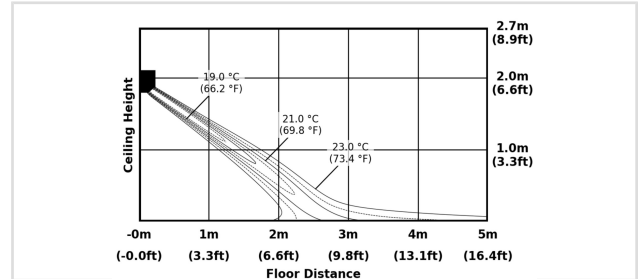

- Heating AirVelocity Distribution (Discharge Angle : 45 degree)

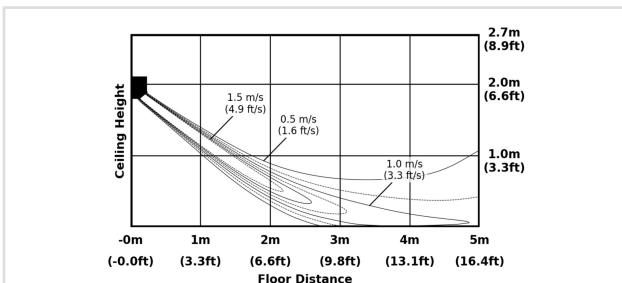

- Heating Temperature Distribution (Discharge Angle : 45 degree)

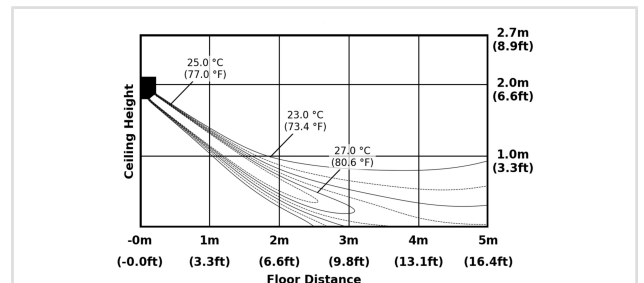

AR70H09C1ABNEU + AR70H09C1AWXEU

- Cooling AirVelocity Distribution (Discharge Angle : 25 degree)

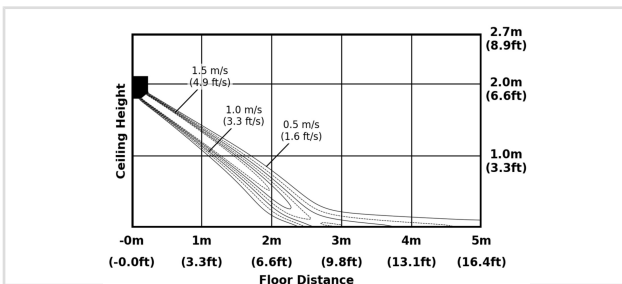

- Cooling Temperature Distribution (Discharge Angle : 25 degree)

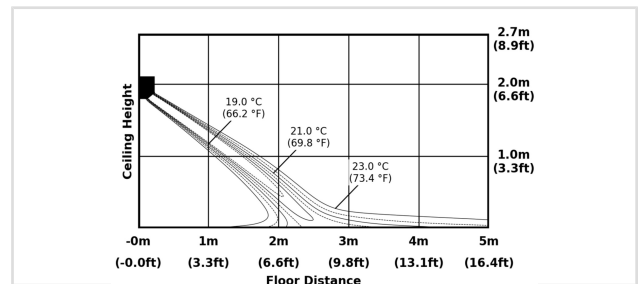

- Heating AirVelocity Distribution (Discharge Angle : 45 degree)

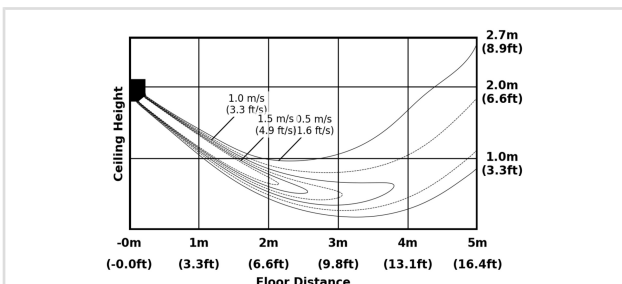

- Heating Temperature Distribution (Discharge Angle : 45 degree)

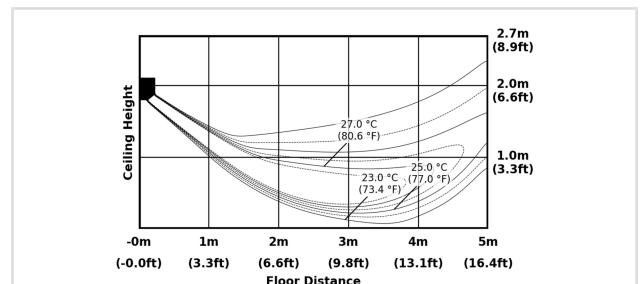

9. Temperature and Air Flow Distribution

Première Black

AR70H12C1ABNEU + AR70H12C1AWXEU

- Cooling AirVelocity Distribution (Discharge Angle : 25 degree)

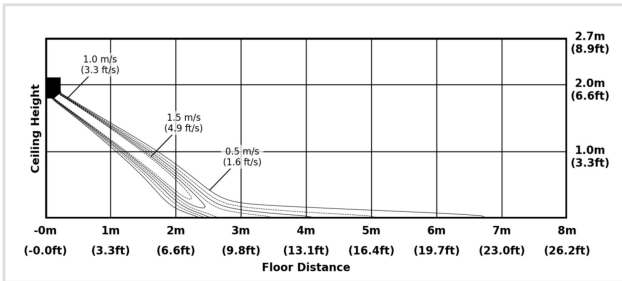

- Cooling Temperature Distribution (Discharge Angle : 25 degree)

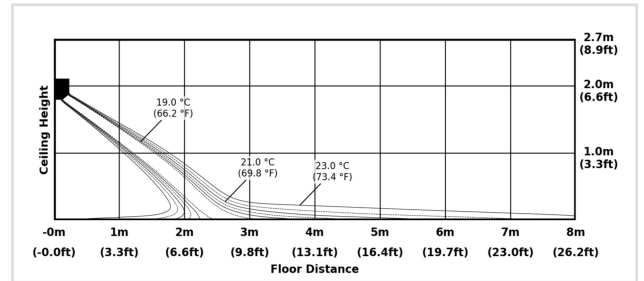

- Heating AirVelocity Distribution (Discharge Angle : 45 degree)

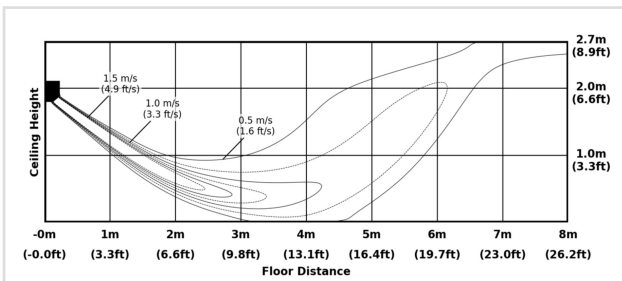

- Heating Temperature Distribution (Discharge Angle : 45 degree)

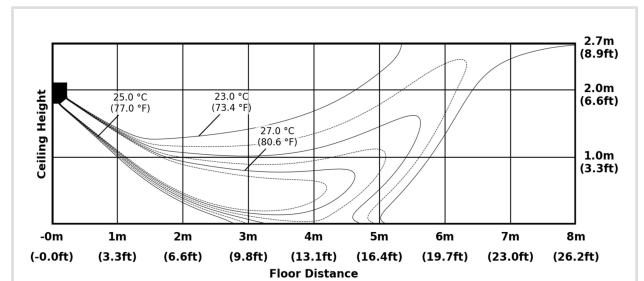

10. Operation Range

Outdoor Unit

• Cooling

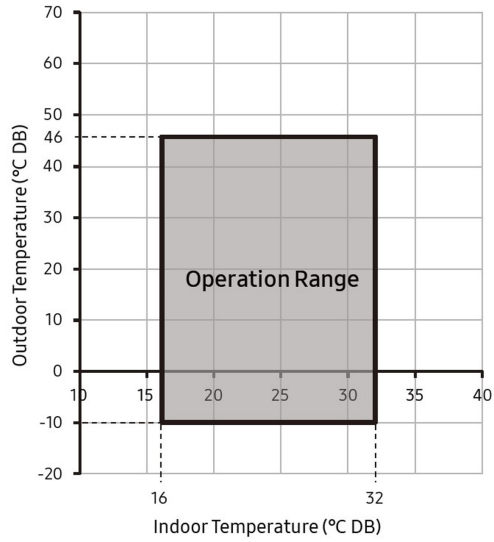

• Heating

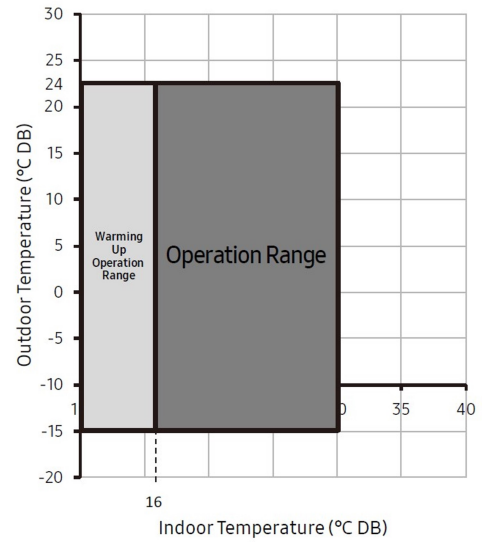

11. Capacity Correction

Outdoor Unit

AR70H07C1AWXEU, AR70H09C1AWXEU, AR70H09CAAWXEU, AR70H12C1AWXEU, AR70H12CAAWXEU
AR70H15C1AWXEU

Cooling

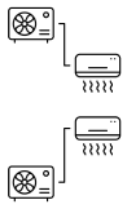

		Piping length (m)				
		5.0	10.0	12.5	15.0	20.0
Level Difference (m)	10.0	-	0.95	0.94	0.93	0.91
	7.0	-	0.96	0.95	0.94	0.92
	5.0	0.99	0.97	0.96	0.95	0.93
	0.0	1.00	0.98	0.97	0.96	0.94
	-5.0	0.99	0.97	0.96	0.95	0.93
	-7.0	-	0.96	0.95	0.94	0.92
	-10.0	-	0.95	0.94	0.93	0.91

Heating

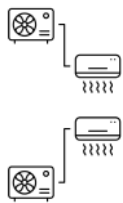

		Piping length (m)				
		5.0	10.0	12.5	15.0	20.0
Level Difference (m)	10.0	-	0.95	0.94	0.93	0.91
	7.0	-	0.96	0.95	0.94	0.92
	5.0	0.99	0.97	0.96	0.95	0.93
	0.0	1.00	0.98	0.97	0.96	0.94
	-5.0	0.99	0.97	0.96	0.95	0.93
	-7.0	-	0.96	0.95	0.94	0.92
	-10.0	-	0.95	0.94	0.93	0.91

11. Capacity Correction

Outdoor Unit

AR70H18C1AWXEU, AR70H24C1AWXEU

Cooling

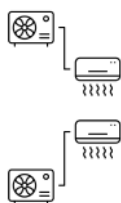

		Piping length (m)						
		5.0	10.0	12.5	15.0	20.0	25.0	30.0
Level Difference (m)	15.0	-	-	-	0.92	0.90	0.88	0.86
	10.0	-	0.95	0.94	0.93	0.91	0.89	0.87
	7.0	-	0.96	0.95	0.94	0.92	0.90	0.88
	5.0	0.99	0.97	0.96	0.95	0.93	0.91	0.89
	0.0	1.00	0.98	0.97	0.96	0.94	0.92	0.90
	-5.0	0.99	0.97	0.96	0.95	0.93	0.91	0.89
	-7.0	-	0.96	0.95	0.94	0.92	0.90	0.88
	-10.0	-	0.95	0.94	0.93	0.91	0.89	0.87
	-15.0	-	-	-	0.92	0.90	0.88	0.86

Heating

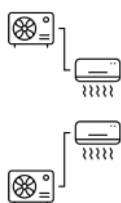

		Piping length (m)						
		5.0	10.0	12.5	15.0	20.0	25.0	30.0
Level Difference (m)	15.0	-	-	-	0.92	0.90	0.88	0.86
	10.0	-	0.95	0.94	0.93	0.91	0.89	0.87
	7.0	-	0.96	0.95	0.94	0.92	0.90	0.88
	5.0	0.99	0.97	0.96	0.95	0.93	0.91	0.89
	0.0	1.00	0.98	0.97	0.96	0.94	0.92	0.90
	-5.0	0.99	0.97	0.96	0.95	0.93	0.91	0.89
	-7.0	-	0.96	0.95	0.94	0.92	0.90	0.88
	-10.0	-	0.95	0.94	0.93	0.91	0.89	0.87
	-15.0	-	-	-	0.92	0.90	0.88	0.86

12. Piping Diagram

AR80H

Cooling

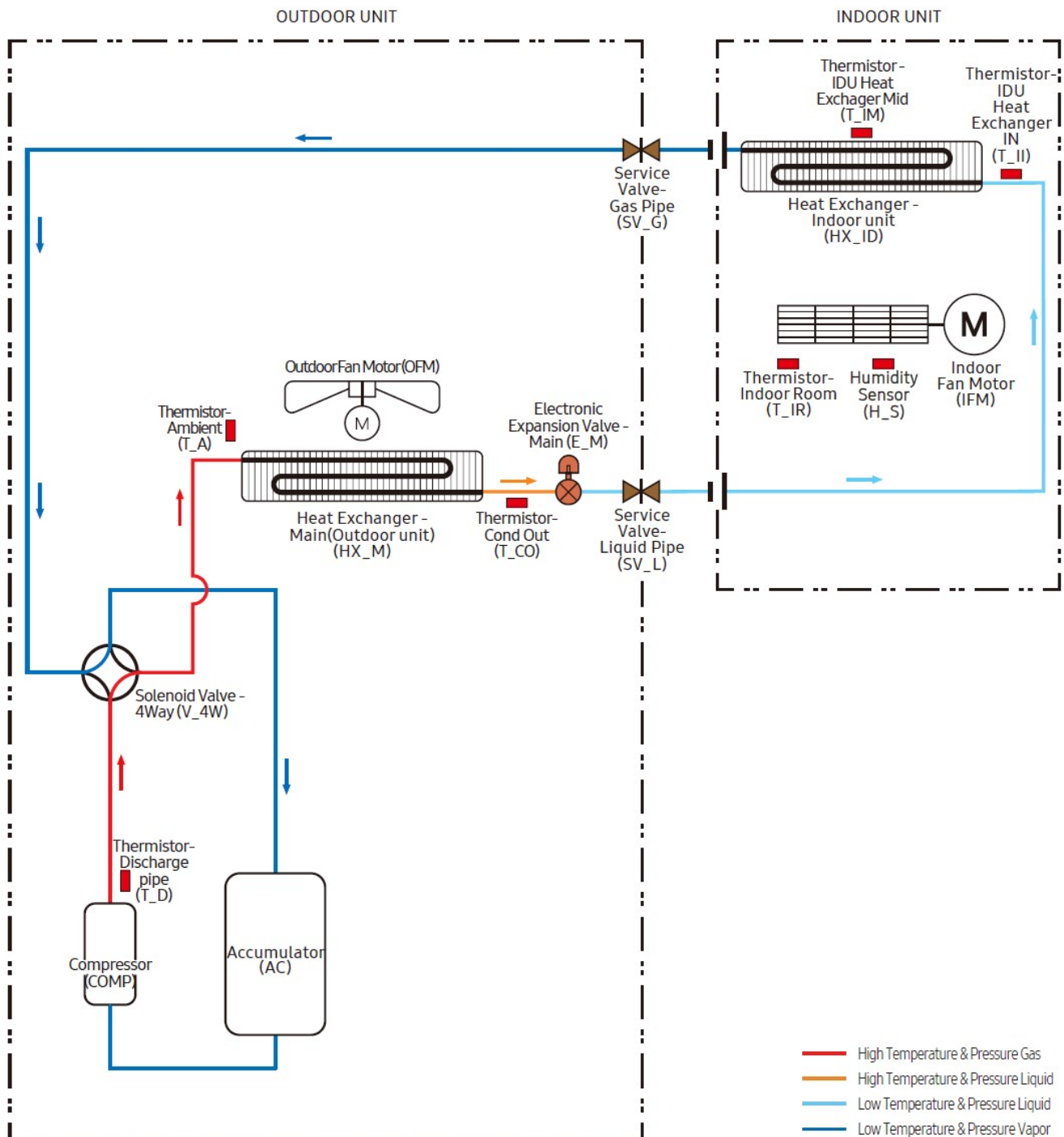

NOTE

- Humidity sensor : only for WindFree models.

12. Piping Diagram

AR80H

Heating

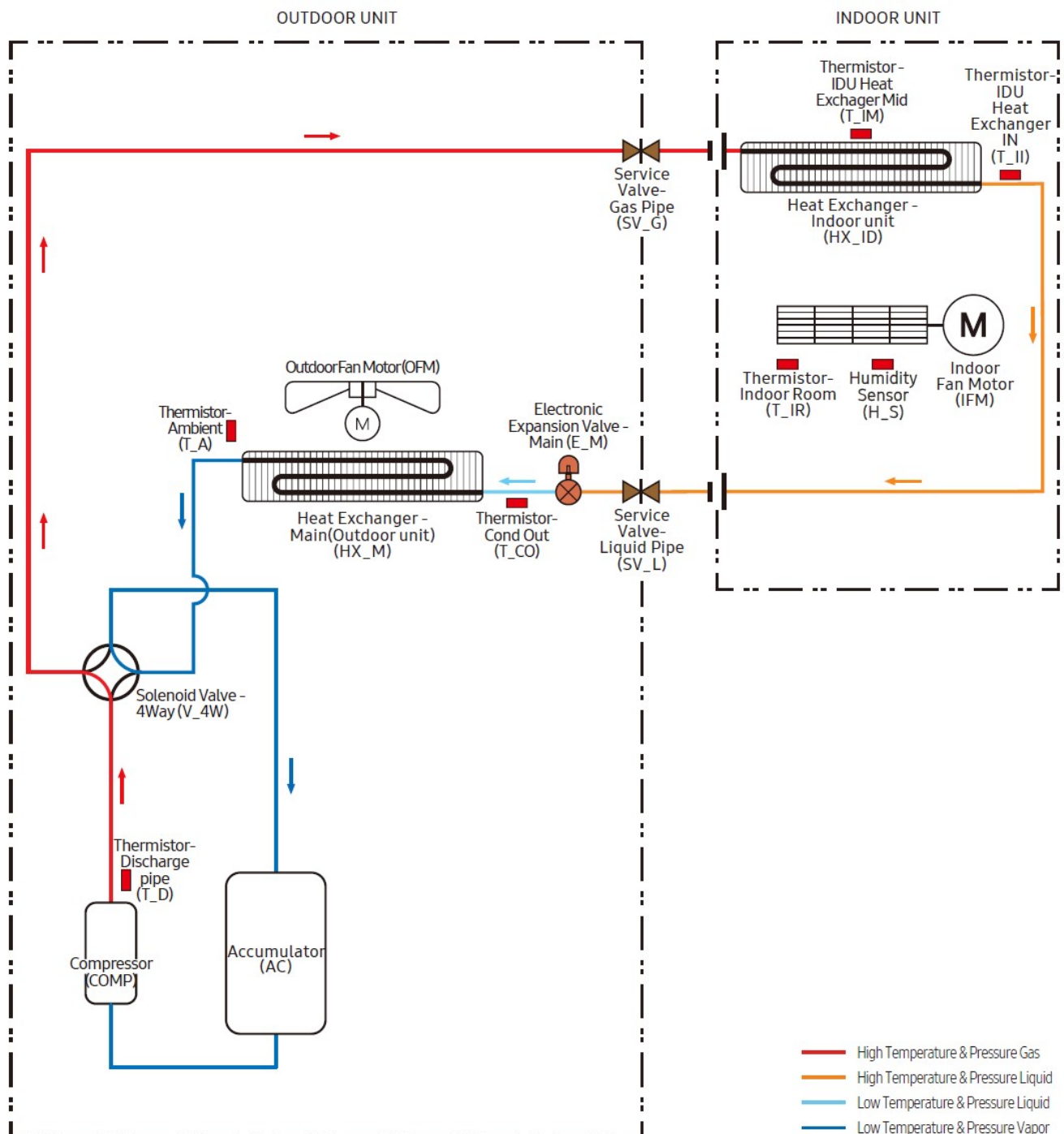

NOTE

- Humidity sensor : only for WindFree models.

✳. Installation

Installation of the product

- Our units must be installed in compliance with the spaces indicated in the installation manual to ensure either accessibility from both sides or ability to perform routine maintenance and repairs. The units' components must be accessible and that can be disassembled in conditions of complete safety either for people or things. For this reason, where it is not observed as indicated into the Installation Manual, the cost necessary to reach and repair the unit (in safety, as required by current regulations in force) with slings, trucks, scaffolding or any other means of elevation won't be considered in-warranty and will be charged to end user.
- The outdoor unit shall be installed in an open space that is always ventilated.
- The local gas regulations shall be observed.
- To handle, purge, and dispose the refrigerant, or break into the refrigerant circuit, the worker should have a certificate from an industry-accredited authority.
- The installation of pipings shall be kept to a minimum.
- Do not install the indoor unit in the following areas:
 - Area filled with minerals, splashed oil, or steam. It will deteriorate plastic parts, causing failure or leakage.
 - Area that is close to heat sources.
 - Area that produces substances such as sulfuric gas, chlorine gas, acid, and alkali. It may cause corrosion of the pipings and brazed joints.
 - Area that can cause leakage of combustible gas and suspension of carbon fibers, flammable dust, or volatile flammables.
 - Area where refrigerant leaks and settles.
 - Area where animals may urinate on the product. Ammonia may be generated.
- Do not use the indoor unit for preservation of food items, plants, equipment, and art works. This may cause deterioration of their quality.
- Do not install the indoor unit if it has any drainage problem.
- Because your air conditioner contains R-32 refrigerant, make sure that it is installed, operated, and stored it in a room whose floor area is larger than the minimum required floor area specified in the following table:

Wall-mounted type	
m (kg)	A (m ²)
≤ 1.842	No requirement
1.843	4.45
1.9	4.58
2.0	4.83
2.2	5.31
2.4	5.79
2.6	6.39
2.8	7.41
3.0	8.51

- m : Total refrigerant charge in the system
- A : Minimum required floor area
- **IMPORTANT:** it's mandatory to consider either the table above or taking into consideration the local law regarding the minimum living space of the premises.
- Minimum installation height of indoor unit is 0.6 m for floor mounted, 1.8 m for wall, 2.2 m for ceiling.
- The actual refrigerant charge shall be in accordance with the room size within which the refrigerant containing parts are installed.
- Make sure that the fan and fan mechanism are operating adequately and the air intake and outlets are not obstructed.
- Marking to the equipment shall continue to be visible and legible. Markings and signs that are illegible shall be corrected.
- Refrigerating pipe or components shall be installed in a position where they are unlikely to be exposed to any substance which may corrode refrigerant containing components, unless the components are constructed of materials which are inherently resistant to corrosion or are suitably protected against this corrosive environment.

✳. Installation

Viewing the typical installation

A typical installation will be similar to the one shown below.

(Unit : m)

Model	Pipe length			
	Minimum	Maximum	Standard for factory charge	Maximum Height
AR70*07***** AR70*09***** AR70*12***** AR70*15*****	3	20	7.5	10
AR70*18***** AR70*24*****	3	30	7.5	15

Outdoor Unit
Outer wall
Indoor Unit

Cut insulation to have rainwater drained

⚠ Make a U-trap (A) on the pipe (which is connected to the indoor unit) at outer wall and cut the bottom part of the insulation (about 10 mm) to prevent rainwater from getting inside through the insulation.

⚠ CAUTION

- For the product that uses the R-32 refrigerant, Install the indoor unit on the wall 1.8 m or higher from the floor.

✖. Installation

Choosing the installation location

If using a multi split system, install as described in the installation manual supplied with the outdoor unit.

WARNING

- Verify that a dedicated circuit breaker and a disconnect switch of the appropriate sizes for the air conditioner are preinstalled and available for use.
- Verify that the voltage and frequency of the power supply comply with the rated voltage as defined on the unit name plate.
- Verify that a suitable grounding connection is available.
- Do not install this appliance in an environment containing hazardous substances or close to equipment that releases open flames.
- Do not install this appliance near a heater or flammable material.

CAUTION

- The manufacturer shall not be responsible for damage occurring as a result of the wrong voltage being applied to this air conditioner.
- The indoor and outdoor units must be installed in compliance with minimum clearances to ensure that both units are accessible from both sides and can be maintained or repaired. Insufficient clearance may reduce product performance, generate excessive noise, and reduce the life of some unit components.

IMPORTANT

- Any changes or modifications to the installation described in this manual that are not expressly approved by the manufacturer could void the manufacturer's warranty.

To determine where to locate the indoor and outdoor units, you must survey the entire site and consider many variables. The goal is to select locations that comply with all safety precautions while also minimizing the total effort involved.

✖. Installation

Indoor unit location requirements

WARNING

- Do not install the unit in a humid, oily, or dusty location or in a location exposed to direct sunlight, water, or rain.
- Make sure that the wall can support the unit weight.

Examine the area that the customer wants to be air conditioned. Consider the following:

- What wall location will meet minimum clearances and provide optimal product performance?
- Will the wall provide adequate support for the unit weight (wall with stud construction or concrete)? If applicable, where are the studs?
- Where will you place the wall penetration for routing the piping bundle (consisting of power and communication cables, refrigerant pipes, and the drain hose) through the wall to the outdoor unit? Will the hole intersect any plumbing or wires in the wall?
- Will the condensate drain pipe run from the indoor unit to outside the home so that condensate water will naturally flow outside by gravity or will the drain pipe be connected to a condensate pump?

NOTE

- This manual covers a typical gravity-drain installation where the drain hose is routed to the outdoor unit through a hole in the wall.

Minimum clearances for the indoor unit

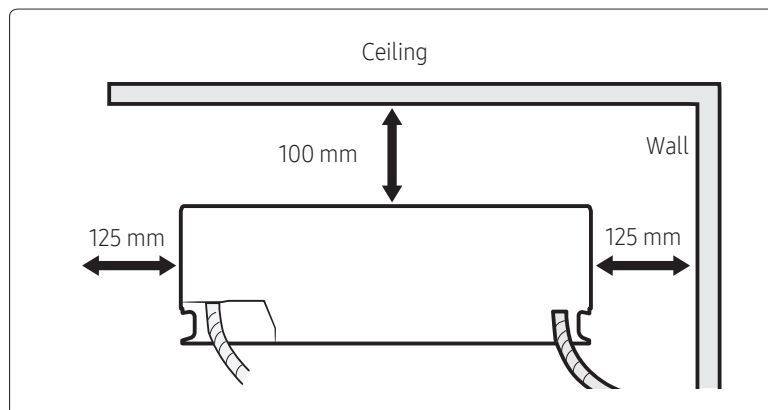

✖. Installation

Outdoor unit location requirements

Examine the area where the outdoor unit could be located. Consider the following:

- What location will meet minimum clearances and provide optimal product performance?
- Is there an existing level and hard foundation, such as a concrete pad, that will support the unit weight and produce minimal vibration? Installation on uneven ground may result in abnormal vibrations, noise, or problems with the unit.
- Does the unit need to be mounted on the wall?
- Where are the dedicated circuit breaker and disconnect switch located? How will you connect them to the unit?
- How will you route the piping bundle from the indoor unit? Is the location as close as possible to where the indoor unit will be installed, to minimize the length of pipe and cables and at the same time ensure the required minimum piping length?
- Will the unit be sheltered from the wind? In a high-wind area, you may need to build a protective fence around the unit.
- Where will the condensate drain be installed?

WARNING

- The drain location must allow condensate to drain properly and prevent ice from forming on the unit in winter. If a block of ice falls from the unit, it may result in death, serious injury, or property damage. Improper or inadequate draining may result in water overflowing and property damage.

CAUTION

- Do not connect the drain hose to existing waste pipes as odors may arise.

Installation on an exterior wall

If the outdoor unit must be installed on an exterior wall, you will need an L-bracket to support the unit. This bracket is not included with the unit.

WARNING

- The wall must be capable of supporting the weight of both the L-bracket and the outdoor unit. If the unit falls, it may result in crushing, electric shock, fire, or explosion that could cause death, severe personal injury, or property damage.
-

※. Installation

Installation Guide at the seashore

Make sure to follow below guides when installing at the seashore.

- 1 Do not install the product in a place where it is directly exposed to sea water and sea breeze.
 - Make sure to install the product behind a structure (such as building) that can block sea breeze.
 - Even when it is inevitable to install the product in seashore, make sure that product is not directly exposed to sea breeze by installing a protection wall.
 - 2 Consider that the salinity particles clinging to the external panels should be sufficiently washed out.
 - 3 Because the residual water at the bottom of the outdoor unit significantly promotes corrosion, make sure that the unit is absolutely level so that the slope of the drain pan does not disturb drainage.
 - Keep the floor level so that rain does not accumulate.
 - Be careful that the drain hole will never be blocked.
 - 4 When product is installed in seashore, periodically clean it with water to remove attached salinity.
 - 5 Make sure to install the product in a place that provides smooth water drainage. Especially, ensure that the base part has good drainage.
 - 6 If the product is damaged during the installation or maintenance, make sure to repair it.
 - 7 Check the condition of the product periodically.
 - Check the installation site every 3 months and perform anti-corrosion treatment such as commercial water repellent grease and wax, etc., based on the product condition.
 - When the product is to be shut down for a long period of time, such as off-peak hours, take appropriate measures like covering the product.
 - 8 If the product installed within 500m of seashore, special anti-corrosion treatment is required.
 - ※ Please contact your local SAMSUNG representative for further details.
-

✳. Installation

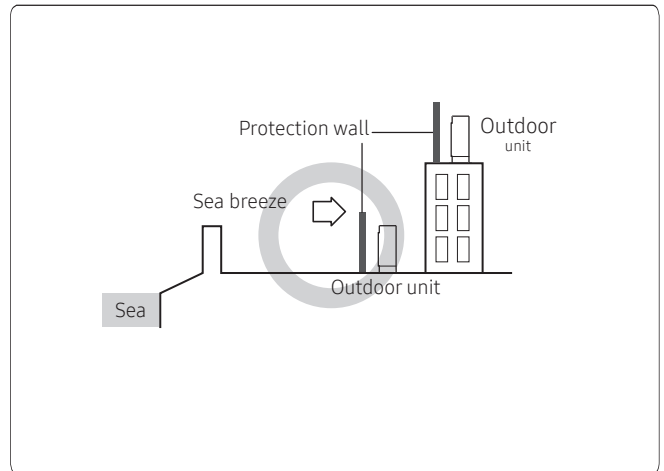
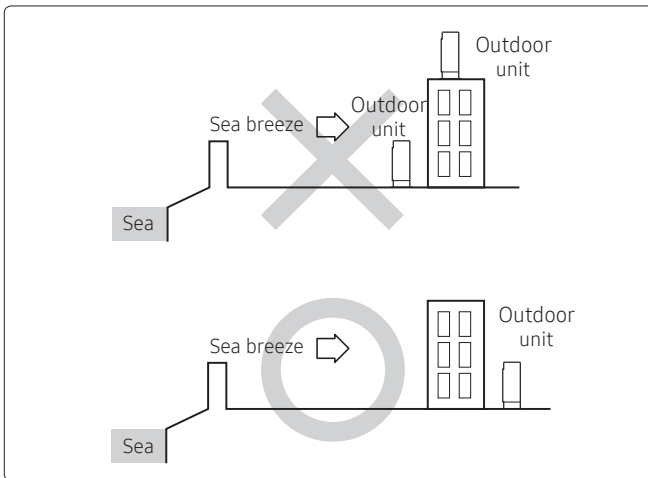

- Protection wall should be constructed with a solid material that can block the sea breeze and the height and width of the wall should be 1.5 times larger than the size of the outdoor unit. (You must secure more than 600 mm of space between the protection wall and the outdoor unit for air circulation.)

Minimum clearances for the outdoor unit

If there is an obstacle in front of the air vent, keep the outdoor unit at a distance of at least 700 mm from the obstacle.

Legends:

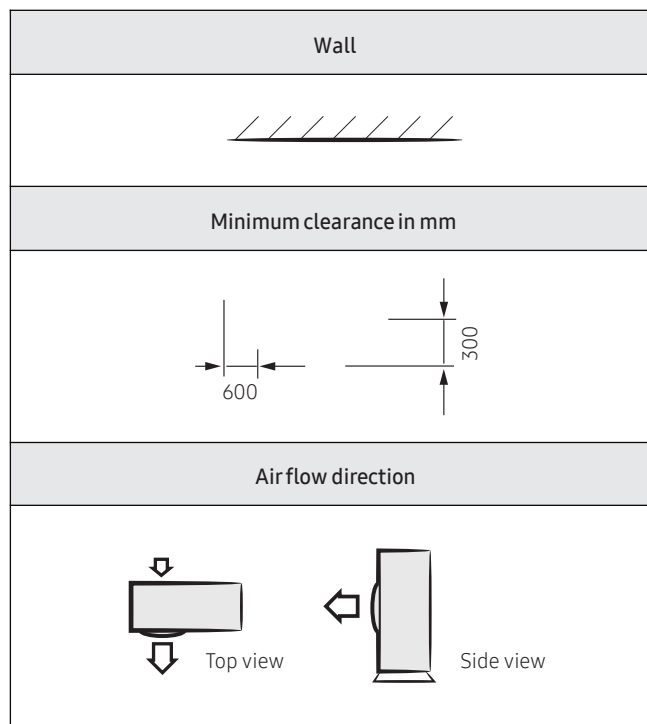

※. Installation

Examples for installing one outdoor unit:

Unit: mm

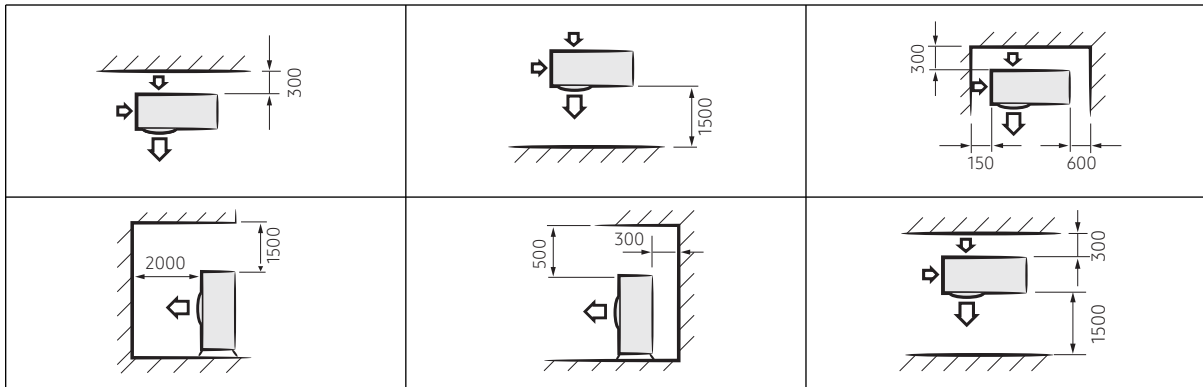

Examples for installing multiple outdoor units:

Unit: mm

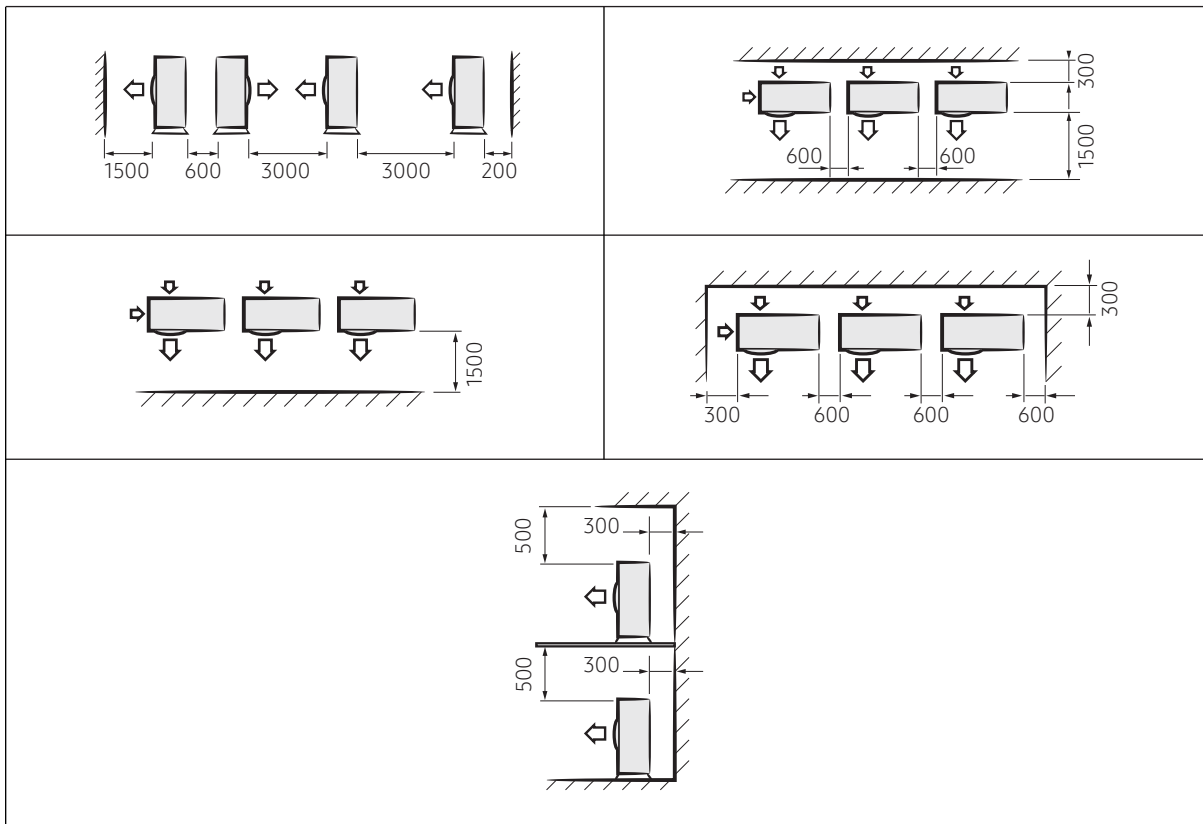

✖. Installation

Indoor Unit Installation

Attaching the mounting bracket to the wall

- 1 Hold the mounting bracket against the wall at the selected installation position making sure that the screw holes align with the center of the studs in the wall. If the screw locations do not align with the studs, use wall anchors.

CAUTION

- The recommended best practice is to attach the mounting bracket directly to the studs in the wall. If you did not find a suitable location with studs, or if the wall is concrete, you must use wall anchors of a suitable type and weight capacity, and install them according to the manufacturer's instructions. Failure to do so may cause the material surrounding the joints to crumble over time and the screws to come loose from the wall. This may result in the unit falling from the wall, which could cause physical injury or equipment damage.
- 2 Using a level, make sure that the mounting bracket is level, then mark the location of the screw holes on the wall.
 - 3 If using wall anchors, install them at the screw hole positions, following the manufacturer's instructions.
 - 4 Using six field-supplied mounting screws and anchors (if applicable), attach the bracket to the wall.

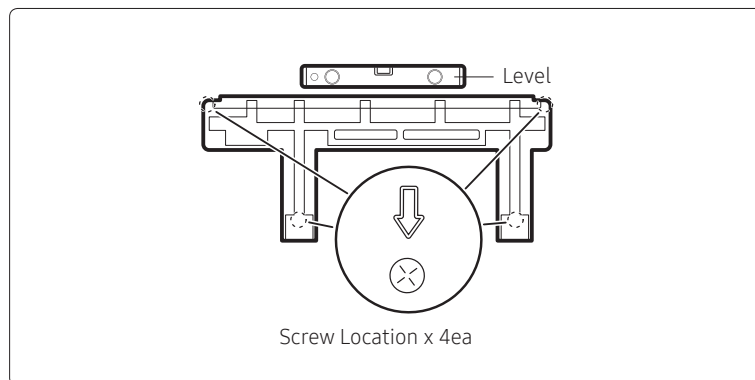

✳. Installation

Indoor Unit Installation

Drilling the wall penetration

- 1 Determine the position of the hole through which the piping bundle (consisting of power and communication cables, refrigerant pipes, and the drain hose) will pass. Consider the following:
 - The hole inner diameter must be 65 mm.
 - The recommended hole location is behind the unit so that the hole and the piping bundle will not be visible in the room. The minimum distances between the hole and the mounting bracket are:

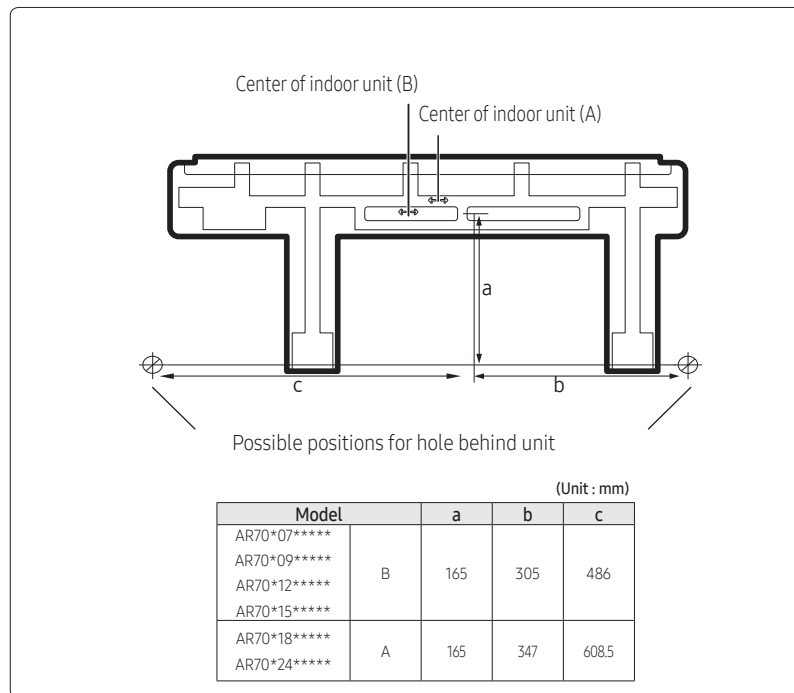

- If the hole cannot be positioned behind the unit, find a position as close to the unit as possible. The piping bundle that exits the unit and extends to the hole will need to be attached to the wall and will be visible inside the room.
- In relation to the bracket shown above, the unit is shipped with the drain hose connection on the right, the drain hose exits the unit on the left, and the refrigerant pipes are bent to exit on the left. Thus, positioning the hole to the left requires the least effort. If you position the hole to the right or below the unit, you will need to move the drain hose connection to the left and bend the pipes so that the hose and pipes exit to the right or bottom.

NOTE

- Pull the centre of the cover panel to remove the hook (1) and then pull the left corner (2) and right corner (3) in sequence to remove the cover panel.

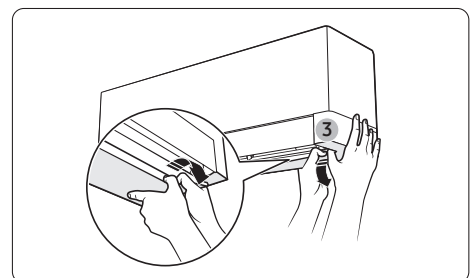
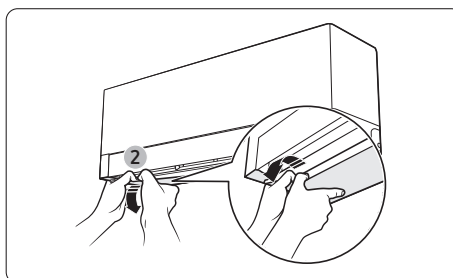
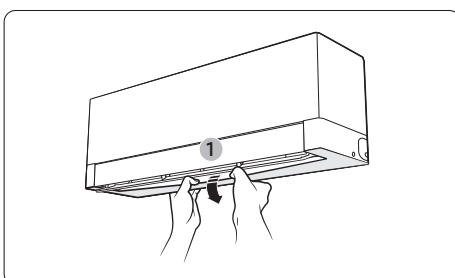

✳. Installation

Indoor Unit Installation

- 2 Use a standard 65 mm hole saw to drill one hole at the selected location, at a 15° downward angle so that the drain hose will drain properly.

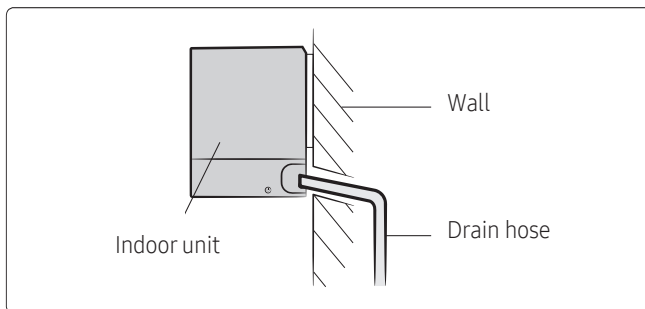

- 3 Based on the hole location, determine where the piping bundle (drain hose, refrigerant pipes, and cables) will exit the unit.

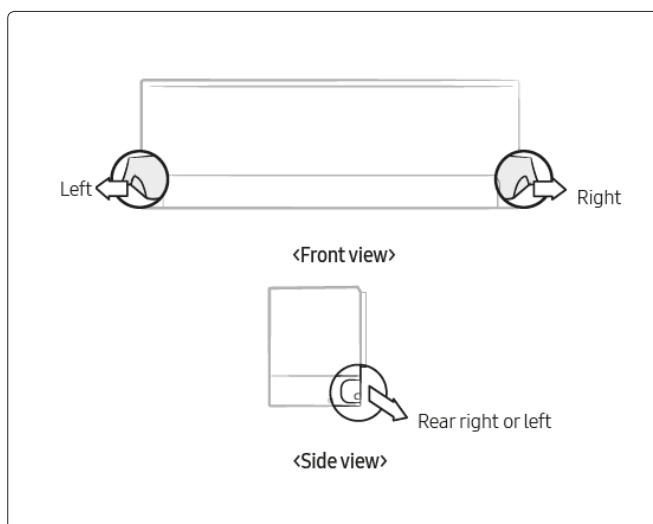

📄 NOTE

- The left, right, or bottom exit will only be used if the hole is not positioned behind the unit.

✳. Installation

Connecting the power and communication cables

If using a multi split system, install as described in the installation manual supplied with the outdoor unit.







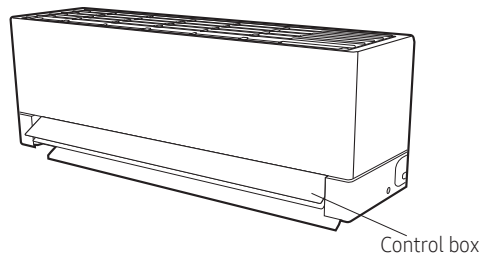

⚠ WARNING

- Do not modify the power cable in any way. Doing so may cause electric shock or fire due to poor connection, poor insulation, or current limit override. Make sure to comply with the technical standards of electrical installations and the wiring regulations in the local area.
- This appliance must be properly grounded. Do not ground the appliance to a gas pipe, plastic water pipe, or telephone line. Failure to comply may result in electric shock, fire, and explosion.
- Make sure that cabling is not subject to wear, corrosion, excessive pressure, vibration, sharp edges, or adverse environmental effects. Take into account the effects of aging or continual vibration from sources such as compressors or fans.

1 Connect each wire to its corresponding terminal number.

Model	AR70*07***** AR70*09***** AR70*12***** AR70*15*****	AR70*18***** AR70*24*****
Power cable (Outdoor unit)	3G X 2.5 mm ² , H07RN-F	3G X 2.5 mm ² , H07RN-F
Outdoor-to-indoor power cable	3G X 1.0 mm ² , H07RN-F	3G X 1.0 mm ² , H07RN-F
Communication cable	2 X 0.75 mm ² , H05RN-F	2 X 0.75 mm ² , H05RN-F
Type GL 	16A	20A



Before connecting				
	Correct	Upside down	Damaged	Non-circular
After connecting				
	Correct (Front view)	Correct (Side view)	Upside down	Non-fitted

<Circular terminal>

✖. Installation

⚠ CAUTION

- Connect the wires firmly so that wires cannot be pulled out. Loose wires can cause the connection to overheat. Each circular terminal must match the size of its corresponding screw in the terminal block.

⚠ CAUTION

- For the terminal block wiring, use a wire with a ring terminal socket only. Regular wires without a ring terminal socket may become a hazard as the connections may loosen during operation.

For the product that uses the R-32 refrigerant, be cautious not to generate a spark by keeping the following requirements:

- Do not remove the fuses with power on.
- Do not disconnect the power plug from the wall outlet with power on.
- It is recommended to locate the outlet in a high position. Place the cords so that they are not tangled.

- 2 Tighten the terminal block screw.

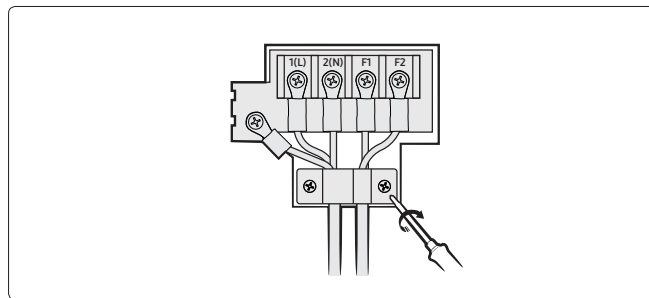

- 3 You determined the exit position for the piping bundle. If using the left, right, or bottom exits, pass the cables through the selected knockout.

📄 NOTE

- Power supply cords of parts of appliances for outdoor use shall not be lighter than polychloroprene sheathed flexible cord. (Code designation IEC: 60245 IEC66/CENELEC: H07RN-F, IEC: 60245 IEC57 CENELEC: H05RN-F, IEC: 60227 IEC53: H05VV-F)
 - Power & Communication cable shall not exceed 30 m.
-

✳. Installation

Outdoor Unit Installation

If using a multi split system, install as described in the installation manual supplied with the outdoor unit.

Mounting the outdoor unit

To promote proper condensate draining, the recommended installation of the outdoor unit is elevated above the ground on a mounting bracket attached to a concrete pad.

In areas where snowfall occurs, the unit must be mounted above the snow line to allow for proper heating. Snow cannot be allowed to collect on top of the unit. For promoting natural drainage in a heavy snow fall area:

- For promoting natural drainage in heavy snow fall area: Install the unit high enough of the ground to prevent the unit from being buried by snow. Depending on the estimated snow fall in the area there should be 80 mm or more of clearance. (Ensure that the drained water runs off correctly and safely.)
- Allow enough separation distance between the product and the ground.

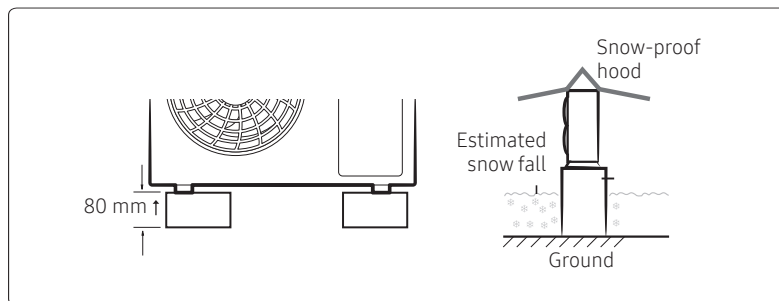

On the ground

- 1 Place the outdoor unit in the selected installation location, ensuring proper clearances and with the arrow on top of the unit pointing away from the wall.
- 2 Clip the rubber feet to the tabs to minimize sound and vibration to the structure.

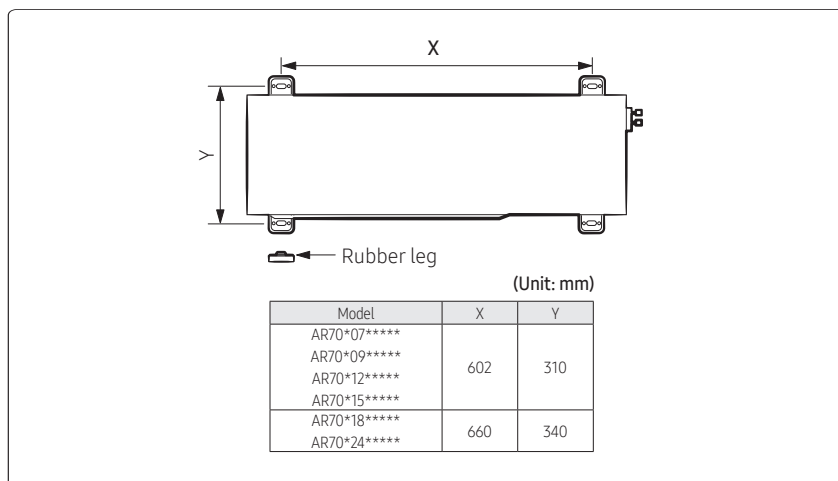

- 3 Level the unit, then use anchor bolts to secure it at the four mounting points.
- 4 For installations in locations that require seismic or hurricane tie downs, comply with local codes.
- 5 If the selected location is exposed to strong winds, install a protective fence around the unit so that the fan can operate correctly.

✖. Installation

Outdoor Unit Installation

On a wall

WARNING

- The unit must be properly secured to the wall. If the unit falls, it may result in crushing, electric shock, fire, or explosion that could cause death, severe personal injury, or property damage.

- 1 At the selected installation location attach the L-bracket to the wall as follows:
 - Install the bracket as close to the wall as possible.
 - Insert rubber isolators between the bracket and the wall to minimize sound and vibration to the structure. Do not fully compress the isolators.

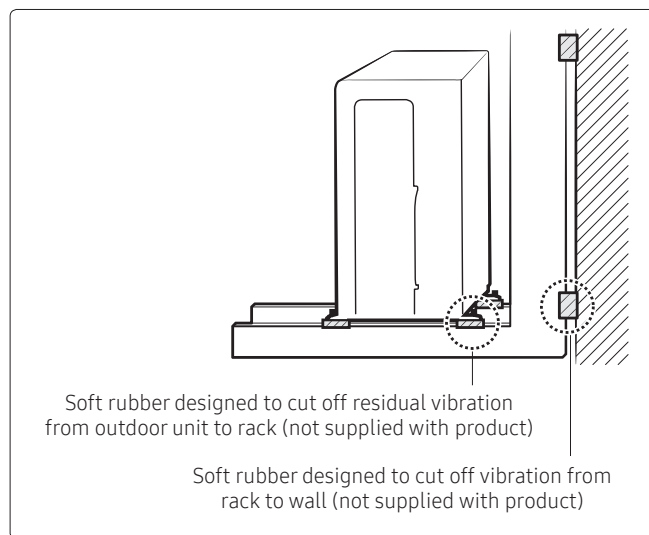

- Make sure that the bracket is level.
 - Use suitable bolts/washers and lock washers.
- 2 Place the outdoor unit on the bracket, ensuring proper clearances and with the arrow on top of the unit pointing away from the wall.
 - 3 Clip the rubber feet to the tabs to minimize sound and vibration to the structure.
 - 4 Level the unit, then use anchor bolts to secure it at the four mounting points.
 - 5 For installations in locations that require seismic or hurricane tie downs, comply with local codes.
-

✳. Installation

Outdoor Unit Installation

Adding refrigerant (if needed)

As is shown on the outdoor unit label, the standard pipe length between indoor and outdoor unit is 5m. This 5m is the standard pipe length of performance specification test in Europe, however, the outdoor unit is charged with sufficient R-32 refrigerant to support up to a 7.5m line set. For lengths greater than 7.5m you must add 15 g of refrigerant per meter of additional length, after the lines are evacuated.

1 Calculated the additional refrigerant required;

Additional grams of R-32 = (Total line set meter -7.5) * 15

2 Connect the common hose of the manifold gauge set to the inverted R-32 refrigerant cylinder.

3 Place the refrigerant cylinder on a scale set to measure grams.

4 Open the valve on the tank.

5 At the manifold connection, bleed the refrigerant to remove any air that may be present in the common hose. 6 Open the gauge manifold and charge the system with the amount of refrigerant calculated.

7 Close the gauge manifold valve, close the valve on the refrigerant tank, and remove the common hose.

Precautions on adding the R-32 refrigerant

In addition to the conventional charging procedure, the following requirements shall be kept.

- Make sure that contamination by other refrigerants does not occur for charging.
 - To minimize the amount of refrigerant, keep the hoses and lines as short as possible.
 - The cylinders shall be kept upright.
 - Make sure that the refrigeration system is earthed before charging.
 - Label the system after charging, if necessary.
 - Extreme care is required not to overcharge the system.
 - Before recharging, the pressure shall be checked with nitrogen blowing.
 - After charging, check for leakage before commissioning.
 - Be sure to check for leakage before leaving the work area.
-

✖. Installation

Outdoor Unit Installation

Important information: regulation regarding the refrigerant used

This product contains fluorinated greenhouse gases. Do not vent gases into the atmosphere.

⚠ CAUTION

- Inform user if the system contains 5 tCO₂e or more of fluorinated greenhouse gases. In this case, it must be checked for leakage at least once every 12 months, according to regulation No. 517/2014. This activity must be covered by qualified personnel only. In the case of the situation above, the installer (or authorized person with responsibility for final check) must provide a maintenance book, with all the information recorded, according to REGULATION (EU) No. 517/2014 OF THE EUROPEAN PARLIAMENT AND OF THE COUNCIL of 16 April 2014 on fluorinated greenhouse gases.
- 1 Please fill in the following with indelible ink on the refrigerant charge label supplied with this product and on this manual.
- ① the factory refrigerant charge of the product,
 - ② the additional refrigerant amount charged in the field and
 - ①+② the total refrigerant charge. on the refrigerant charge label supplied with the product.

Refrigerant type	GWP value
R-32	675

- GWP: Global Warming Potential
- Calculating tCO₂e: kg x GWP/1000

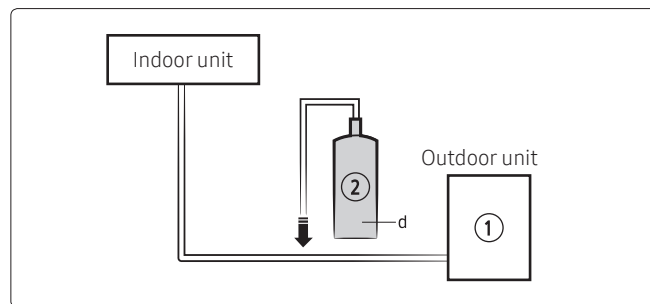

Unit	Kg	tCO ₂ e
①, a		
②, b		
①+②, c		

✖. Installation

Outdoor Unit Installation

NOTE

- a Factory refrigerant charge of the product: see unit name plate
- b Additional refrigerant amount charged in the field
(Refer to the above information for the quantity of refrigerant replenishment.)
- c Total refrigerant charge
- d Refrigerant cylinder and manifold for charging

CAUTION

- The filled-out label must be adhered in the proximity of the product charging port (e.g. onto the inside of the stop valve cover).
- Make sure that the total refrigerant charge does not exceed (A), the maximum refrigerant charge, which is calculated in the following formula: Maximum refrigerant charge (A)= factory refrigerant charge (B) + maximum additional refrigerant charge due to piping extension (C)
- Here below, the summary table with refrigerant charge limits for each products.

(Unit:g)

Model name	gram		
	A	B	C
AR70*09CA*** AR70*12CA***	1152.5	965	1875
AR70*07C1*** AR70*09C1*** AR70*12C1*** AR70*15*****	1137.5	950	1875
AR70*18***** AR70*24*****	1637.5	1300	337.5

2025.12
Ver. 1.0

Samsung Electronics Co., LTD.

Head Office (Suwon Korea) 129, Samsung-Ro, Yeongtong-Gu, Suwon City, Gyeonggi-Do, Korea 16677

Website : www.samsung.com, <https://hvachub.samsung.com> Email : hvachub@samsung.com

Images and data in this book may subject to change without prior notice.